

truck&camper

2020



VITRIFRIGO
COOL AND BEYOND

FREEZE YOUR MOMENTS



RENDI UNICO OGNI MOMENTO SPECIALE

INNOVAZIONE, DESIGN E ECOSOSTENIBILITÀ:

è la Mission di Vitrifrigo e fa parte di una più ampia strategia aziendale volta al profondo rispetto degli obblighi ambientali.

Abbiamo dato vita ad una vera e propria politica per continuare il nostro impegno a operare come società responsabile, coinvolgendo direttamente o indirettamente tutti gli aspetti delle attività aziendali: progettazione, ingegneria, produzione, manutenzione dei prodotti o distribuzione delle loro parti.

In linea con questa politica, Vitrifrigo ha investito risorse multiple per rinnovare le serie dei prodotti integrando soluzioni a basso GWP e Gas Naturale.



MAKE EVERY SPECIAL MOMENT UNIQUE

INNOVATION, DESIGN AND **ECO-SUSTAINABILITY**:

This is the fundamental core of Vitrifrigo and is part of a broader corporate strategy aimed at respecting environmental obligations.

We have developed a policy to continue our commitment to operate as a responsible company. This covers every aspect of the company's activities, whether directly or indirectly involved in the design, engineering, manufacturing, maintenance of our products, or distribution of their parts.

In line with this policy, Vitrifrigo has invested multiple resources to renew the ranges of products with low GWP and Natural Gas solutions.

MADE IN ITALY





STRATOS
Climatizzatori da tetto
ad uso stazionario

*Roof air conditioners
for stationary use*

8



ROADWIND
Climatizzatori da tetto
ad uso stazionario

*Roof air conditioners
for stationary use*

12



**Frigoriferi e freezer
trivalenti**

*3 ways refrigerators
and freezers*

24



ROADWIND
Climatizzatori da parete
ad uso stazionario

*Wall air conditioners
for stationary use*

16



**Frigoriferi da incasso
per installazioni speciali**

*Built-in refrigerators
for special installations*

18



**Frigoriferi e freezer
con unità interna/esterna**

*Refrigerators and freezers
with built-in/remote cooling unit*

32



**Frigoriferi
portatili**

*Portable
refrigerators*

46

STRATOS - Climatizzatore da tetto ad uso stazionario

COMFORT, SICUREZZA ED EFFICIENZA DI LIVELLO SUPERIORE

Il nuovo climatizzatore da tetto STRATOS offre soluzioni adatte praticamente a qualsiasi automezzo industriale attualmente in circolazione.

Progettato per ottenere la massima efficienza e il minor consumo, rappresenta la risposta più valida alle esigenze di condizionamento all'interno della cabina guida.

I climatizzatori Vitrefrigo, alimentati direttamente dalle batterie del veicolo, garantiscono il perfetto compromesso tra ridotto consumo energetico e incremento delle condizioni di benessere, inteso sia come qualità della climatizzazione e della deumidificazione interna che come livello di emissioni di rumore.

Semplici nel loro utilizzo, con flussi d'aria flessibili attraverso diffusori ruotabili singolarmente, possono essere gestiti comodamente dal pannello di controllo integrato o mediante controllo remoto.

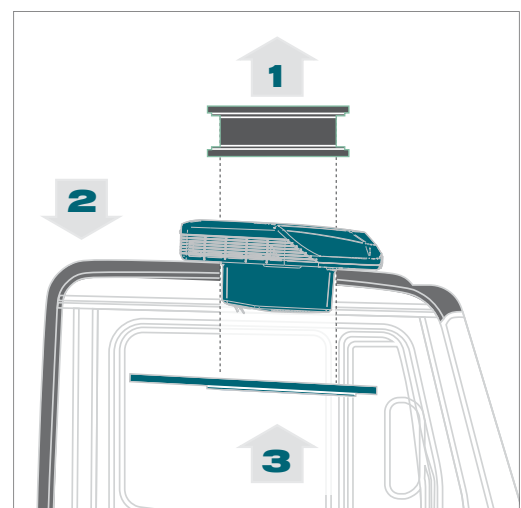

SUPERIOR COMFORT, SAFETY AND EFFICIENCY

The new STRATOS rooftop air conditioner provides solutions for virtually any industrial vehicle currently on the road. Designed for maximum efficiency and minimum consumption, it is the best solution for air conditioning requirements in the driver's cab.

Vitrifigo air conditioners, powered directly by the vehicle battery, guarantee the perfect compromise between energy saving and improved comfort conditions in terms of internal air conditioning quality, dehumidification and sound emissions.

They are simple to use with flexible air flow through individually adjustable air vents which can be easily managed by the integrated control panel or remote control.

STRATOS



INSTALLAZIONE IMMEDIATA

Il nuovo Stratos è dotato di un pianale portante in materiale plastico predisposto per essere montato sui camion dei marchi più diffusi.

- (1) Dopo aver rimosso la botola, è già possibile predisporre il pianale secondo le istruzioni del kit dedicato.
- (2) Installare Stratos sul tetto del camion.
- (3) Montare la cornice in dotazione per completare l'installazione interna.

IMMEDIATE INSTALLATION

The new Stratos is equipped with a self-supporting plastic platform designed to be installed on most popular truck brands.

- (1) after removing the roof hatch, the unit is ready to be installed together with its installation kit.
- (2) Install Stratos on the truck roof.
- (3) Set the supplied flange for completing the internal installation.

STRATOS - Climatizzatore da tetto ad uso stazionario

STRATOS



DESIGN INNOVATIVO PRODOTTO ECOSOSTENIBILE

INNOVATIVE DESIGN
ECO-FRIENDLY PRODUCT



DESIGN
MADE IN ITALY
ITALIAN
DESIGN

Personalità decisa, dalle linee moderne ed eleganti

Strong personality with a modern and elegant style



DESIGN
A 2 PARTI
2 BLOCKS
DESIGN

Nuovo telaio autoportante e cover a prova di intemperie

New self-supporting chassis and storm-proof cover



PIÙ SOTTILE
CHE MAI
THINNER
THAN EVER

Il climatizzatore da tetto con compressore rotativo a profilo più basso (solo 135 mm.)

The thinnest roof air conditioner with rotary compressor (135 mm. only)



AERODINAMICA
AVANZATA
LOW IMPACT
LINE

Progettato con profilo ribassato e aerodinamica avanzata per garantire un carico stradale ridotto

Designed with a low profile and advanced aerodynamics on the front side to ensure a reduced road load



RISPARMIO
ENERGETICO
ENERGY
SAVING

Compressore a inverter di ultima generazione ad alta efficienza e consumo ridotto

Last generation compressor with inverter technology for a high efficiency and reduced power consumption



CERTIFICATO
EMC
EMC
CERTIFIED

Compatibilità per le emissioni elettromagnetiche

Electromagnetic compatibility compliant for the automotive field

TECNOLOGIA AVANZATA INSTALLAZIONE INTELLIGENTE

ADVANCED TECHNOLOGY
SMART INSTALLATION



ALTO POTERE
REFRIGERANTE
HIGH COOLING
POWER

Potere refrigerante pari a 6.000 Btu/h
6.000 Btu/h cooling capacity



USO IN CLIMI
TORRIDI
TROPICAL
USE

Testato per operare con temperature esterne estreme (fino a 43°C ambiente)
Tested for working with hot temp conditions (up to 43° ambient)



TESTATO
A VITA
LIFETIME
TESTED

Certificato in base ai test vibrazionali più restrittivi del settore automotive
Certified according to the strictest automotive vibrational tests



INSTALLAZIONE
RAPIDA
EASY
FIX

Stratos si installa in maniera facile e veloce sui più diffusi veicoli industriali
Stratos can be fast and easily installed on most popular truck brands

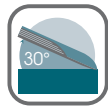

ANGOLAZIONE
ESTREMA
EXTREME
TILT

Installazione a tetto fino a 30°
Roof installation up to 30°



STRATOS

Climatizzatore da tetto ad uso stazionario

STRATOS

Potenza frigorifera - Cooling capacity 6.000 Btu/h

Peso netto - Net weight 22,5 kg.

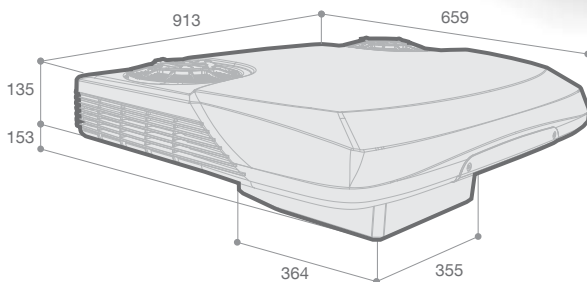

Vedere legenda codici (pag. 58)

See code chart (page 58)

Funzioni e Dotazioni - Features

Regolazione temperatura	Temperature setting	●
Livelli di regolazione velocità ventilatori	Blower speed setting levels	6
Programmi di regolazione potenza: auto, eco, night	Operation settings: auto, eco, night	3
Timer accensione e spegnimento	On/off switching timer	●
Funzione di autodiagnostica	Auto-diagnostic function	●
Funzione salva batteria	Battery saving function	●
Sensore di spegnimento con cabina inclinata	Tilting sensor	●
Tipo di compressore	Compressor type	24Vdc Inverter Rotary
Resa frigorifera max	Max cooling capacity	6000 BTU/h
Peso netto	Net weight	22,5 Kg.
Gas refrigerante	Refrigerant gas	R134a
Numero bocchette orientabili	Rotary air opening	3
Telecomando in dotazione	Supplied remote control	Standard

STRATOS

Roof air conditioner for stationary use



Funzioni telecomando

Remote control functions

- | | | |
|----------|-------------------------------|---------------------|
| 1 | Accensione/spengimento | On/off |
| 2 | Controllo temperatura | Temperature control |
| 3 | Menu | Menu |
| 4 | Timer | Timer |
| 5 | Potenza compressore | Compressor power |
| 6 | Velocità ventilatori | Fan speed |

KIT ACCESSORI - Accessories kit

MARCA BRAND	MODELLO MODEL	CABINA CABIN
DAF	XF XF	SpaceCab Super SpaceCab
IVECO	STRALIS STRALIS	Hi-Road Hi-Way
MERCEDES	ACTROS ACTROS	DayCab BigSpace
RENAULT	T SERIES T SERIES T SERIES	DayCab N&D Cab SleeperCab
SCANIA	R SERIES R SERIES R SERIES	Standard Highline Topline
MAN	TGX	
UNIVERSAL KIT		



OLED
DISPLAY
DISPLAY
OLED

Nuovo display oled luminoso e di semplice utilizzo
New bright and easy to use oled display



TOTAL
CONTROL
CONTROLLO
TOTALE

Nuovo telecomando di ridotte dimensioni con funzione di accensione/spengimento temporizzato
New small size remote control with auto time set function for timed on/off switching



ADVANCED
SETTINGS
FUNZIONI
AVANZATE

3 modalità di funzionamento per avere al meglio:
Auto: massimo della potenza (fino a 1750W)
Eco: massimo della durata (oltre 14 ore)
Night: massimo della silenziosità

3 single settings to get the best:
Auto: max performance (up to 1750 W)
Eco: max operating time (more than 14 hrs)
Night: very low noise level

ROADWIND - Climatizzatori da tetto ad uso stazionario



Funzioni e Dotazioni

Features

		RW7000T	RW3300T
Regolazione temperatura	Temperature setting	●	●
Regolazione velocità ventilatori su 4 livelli	Blower speed setting on 4 levels	●	●
Programmi di regolazione potenza	Programs of cooling power setting	6	3
Funzione orologio e sveglia	Clock and alarm-clock function	●	○
Timer accensione e spegnimento	Switching on-off timer	●	●
Funzione di autodiagnostica	Auto-diagnostic function	●	●
Funzione salva batteria	Battery saving	●	●
Sensore di spegnimento con cabina inclinata	Tilting sensor	●	●
Illuminazione di cortesia a led a luce diffusa	Internal courtesy led light	●	○
Sistema DCS (*)	DCS feature (*)	●	○
Interruttore generale servizio di assistenza	Main power switch for service	●	○
N. compressori a 24Vcc	No. of compressors 24Vdc	2	1
Resa frigorifera max	Max cooling capacity	7.000 Btu/h	3.250 Btu/h
Gas refrigerante	Refrigerant gas	R134A	R134A
Numero bocchette orientabili	Number of rotary air opening	8	4 (**)
Telecomando	Remote control	Standard	Standard

(*) Sistema a Doppio Compressore / Double Compressor System

(**) N. 3 per RW7000T per botola piccola / No. 3 for small roof hatch RW7000T

Vedere legenda codici (pag. 58)

See code chart (page 58)



- POTENTE:** perchè capace di offrire fino a 7000 Btu/h, raggiungendo le massime condizioni di benessere in pochissimi istanti e garantendo un funzionamento supersilenzioso.
- UNIVERSALE:** perchè lo si può montare su qualunque cabina di qualunque veicolo industriale, grazie ai suoi specifici kit di finitura.
- POWERFUL:** because the Roadwind 7000T can offer 7000 BTU/h air-conditioning power, reaching very quickly the best comfort conditions giving you a super-noisless running mode.
- UNIVERSAL:** because you can fit it in every cabin of every truck thanks to its dedicated kits of installation.

UNA CORNICE PER OGNI MODELLO

AN ASSEMBLY KIT FOR EACH MODEL OF TRUCK

		KIT 7000T	KIT 3300T
IVECO	STRALIS	A (0)	A
	EUROCARGO	A	A
	TRAKKER	U	U
VOLVO	FM - FH	B (1)	B (1)
	FH - FM XL	C (2)	C (2)
	FE - FL	D	D
	GLOBETROTTER XL	D	D
RENAULT	MAGNUM	D (3)	D
	PREMIUM STRADA	D	D
	PREMIUM DISTRIBUTION	D	D
	PREMIUM LANDER	D	D
	KERAX	D	D
	RENAULT SERIE T		M
SCANIA	SERIE 4	A (5)	A (4)
	SERIE R	A (5)	A (4)
DAF	CF	F (6)	F (6)
	XF	F (6)	F (6)
	FL	D	D
MAN	TGA	G	G
	TGX	G	G
	TGM	G	G
MERCEDES	ACTROS	H	H
	ACTROS mod. 2012	I	I
	AXOR	U	U
	ATEGO	U	U



(0) Tetto inclinato
Sloping roof

(1) Botola piccola
Small roof hatch

(2) Botola grande
Big roof hatch

(3) Prima del 2008
Before 2008

(4) Apertura manuale
Manual opening

(5) Apertura manuale e elettrica
Manual and electric opening

(6) Eccetto Super SpaceCab
Except for Super SpaceCab

RW7000T

Potenza frigorifera - Cooling capacity 7000 Btu/h

Peso netto - Net weight 50 kg.

Gas refrigerante - Refrigerant gas R134A

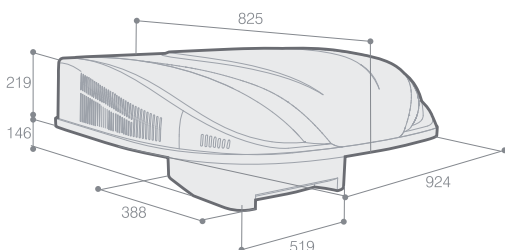
**Funzioni telecomando**

Remote control functions

- | | | |
|----------|------------------------|---------------------|
| 1 | Accensione/spengimento | On/off |
| 2 | Controllo temperatura | Temperature control |
| 3 | Velocità ventilatori | Blowers speed |
| 4 | Potenza compressore | Compressor power |
| 5 | Timer | Timer |

RW3300T

Potenza frigorifera - Cooling capacity	3250 Btu/h
Peso netto - Net weight	25 kg.
Gas refrigerante - Refrigerant gas	R134A

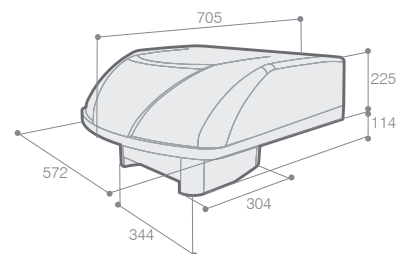

ROADWIND - Climatizzatori da parete ad uso stazionario



I climatizzatori Roadwind 3000 sono una delle risposte più valide alle esigenze di condizionamento nei vani cuccetta dei veicoli industriali. Il nuovo compressore permette l'utilizzo del climatizzatore durante le ore diurne e a motore spento, garantendo un perfetto compromesso tra benessere e basso consumo energetico.

Le dimensioni contenute dell'unità condensatrice, rendono possibile la sua installazione, oltre che a parete, anche a tetto e nel sottocabina.

Grazie alle nuove connessioni con tubo flessibile in rame e acciaio inox antivibrazioni (della lunghezza di 2 mt.) e agli innesti rapidi, si ottiene sicurezza, rapidità d'installazione e qualità di tenuta.

Vitrifrigio è, inoltre, l'unica azienda attualmente sul mercato a fornire l'impianto condizionante precaricato in ogni suo componente.

Unità evaporante: posizionata sulla parete posteriore, permette di rinfrescare la cabina, ottimizzando il condizionamento della zona cuccetta.

Unità condensatrice esterna: studiata per l'installazione sul retro della cabina, è l'unità condensatrice più compatta attualmente presente sul mercato.

The Roadwind 3000 conditioners are one of the ultimate answers to the conditioning needs in the trucks sleeping van. The new compressor allow to use the conditioner during the night time with the engine turned off, always keeping a perfect compromise between wellness and low power consumption.

The most reduced dimension of the condensing unit, made possible its installation, on the cab wall, on the roof and on the bottom of the cab.

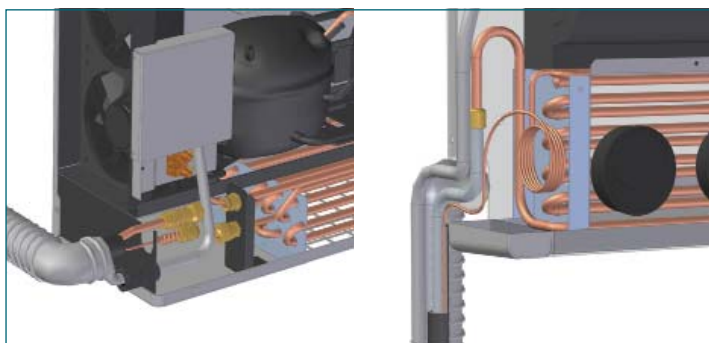

The installation is made easier thanks to the new connections with flexible copper and stainless steel antivibrations pipe (2 meters long), which, together with the easy quick couplings, assure safety, fast installation and quality of resistance.

Moreover, Vitrifrigio is the only company present on the market to supply the conditioning system complete with precharge in each component.

Evaporating unit: placed on the back wall, allows to refresh the cabin, optimizing the sleeping van conditioning.

External condensing unit: Suitably planned for the installation on the cabin rear, thanks to its reduced dimension, it's the most compact condensing unit actually present on the market.

RW3000

Potenza frigorifera - Cooling capacity	3000 Btu/h
Peso netto - Net weight	6 (A) + 19 (B) kg.
Gas refrigerante - Refrigerant gas	R134A
Bocchette orientabili - Rotary air openings	N.4

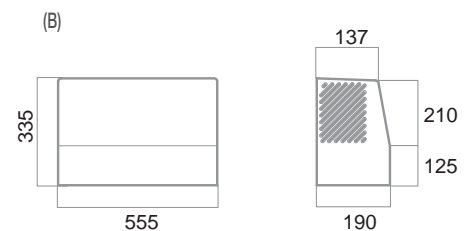
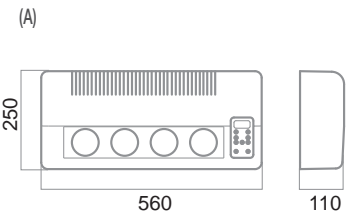

Pannello comandi a microprocessore con display LCD retro illuminato con visualizzazione digitale di:
Control Panel microchip driven with backlight display LCD for digital display of:



- Temperatura ambiente
- Umidità
- Tensione di batteria.
- Timer di spegnimento (0/360 min.)
- Stato compressore (ON/OFF)
- Regolazione ventilazione su 4 livelli
- Regolazione temperatura
- Funzione salva batteria
- 4 bocchette orientabili
- Ambient temperature
- Humidity
- Battery
- Switch off timer (0/360 minutes)
- Compressor state (ON/OFF)
- Ventilation setting on 4 levels
- Temperature setting
- Battery saving function
- 4 Rotary air openings

Telecomando
Remote control



Frigoriferi da incasso per installazioni speciali



M25



V26



V31



S44



BRK35P



C47



C33ip



KIT MAN



BENVENUTI A BORDO

Progettati specificatamente per alcuni modelli di veicoli industriali, sono adatti anche ad installazioni generiche. Sette i modelli disponibili, con capacità variabili da 25 lt. fino a 47 lt., con suddivisione dello spazio interno vano unico, con paratia fissa o mobile e predisposti per ottenere temperature di tipo frigo o frigo-freezer. Disponibili anche due modelli (BRK35P e C47) con il contenitore interno asportabile per una migliore praticità di utilizzo.

WELCOME ABOARD

Designed specifically for some types of industrial vehicle, these models are also suited to generic installation. There are seven versions available, with capacities ranging from 25 through to 47 litres. Space inside is divided as a single compartment with fixed or movable partition and ready to use with fridge or fridge-freezer temperatures. There are also two models (BRK35P and C47) with removable container for easier and more practical use.

	Litri - Liters
M25	25
V26	26
V31	31
S44	35
BRK35P	35
C47	47
C33ip	33
KIT MAN	70 max

Vedere legenda codici (pag. 58)
See code chart (page 58)

Frigoriferi da incasso per installazioni speciali

M25

Capacità - Volume	25 lt.
Peso netto - Net weight	14 kg.
Alimentazione e consumo nominale Power supply and nominal consumption	12 / 24 Vdc 36 W

Specifico per - Suitable for **Mercedes-Benz**

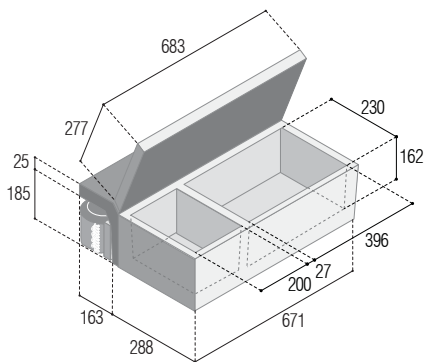

V26

Capacità - Volume	26 lt.
Peso netto - Net weight	14 kg.
Alimentazione e consumo nominale Power supply and nominal consumption	12 / 24 Vdc 36 W

Specifico per - Suitable for **Volvo**

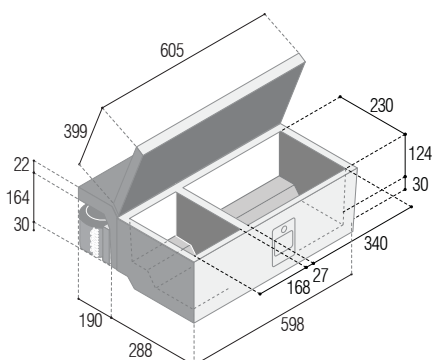

Maniglia non inclusa
Handle not included

V31



Coperchio amovibile - Removable lid



Capacità - Volume	31 lt.
Peso netto - Net weight	16 kg.
Alimentazione e consumo nominale Power supply and nominal consumption	12 / 24 Vdc 36 W

Specifico per - Suitable for **Volvo**

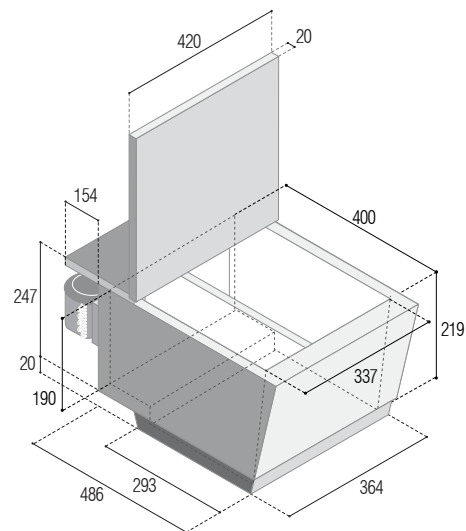

S44

Capacità - Volume	44 lt.
Peso netto - Net weight	16 kg.
Alimentazione e consumo nominale Power supply and nominal consumption	12 / 24 Vdc 36 W

Specifico per - Suitable for **Scania**

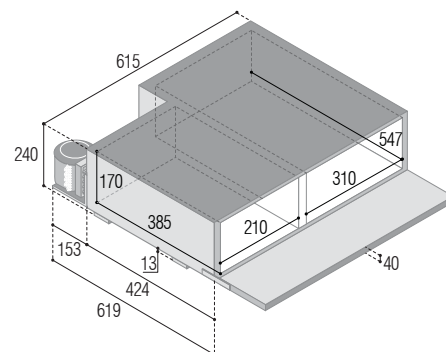

Frigoriferi da incasso per installazioni speciali

BRK35P

Capacità totale - Total volume	35 lt.
Peso netto - Net weight	16 kg.
Alimentazione e consumo nominale Power supply and nominal consumption	12/24 Vdc 31 W



Nuovo sistema di chiusura PUSH-TURN
New PUSH-TURN locking system

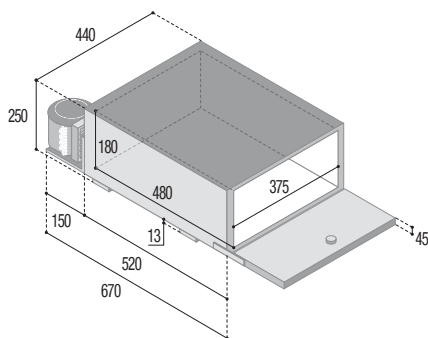

C47

Capacità totale - Total volume	47 lt.
Peso netto - Net weight	19 kg.
Alimentazione e consumo nominale Power supply and nominal consumption	12/24 Vdc 31 W

OPTIONAL

Profilo di fissaggio
Mounting flange

t: 25
w: 588
h: 379

Door Inside

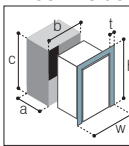

Door Outside

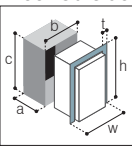

Vano incasso Built-in	a: 676 b: 445 c: 393	a: 633 b: 445 c: 393
--------------------------	----------------------------	----------------------------

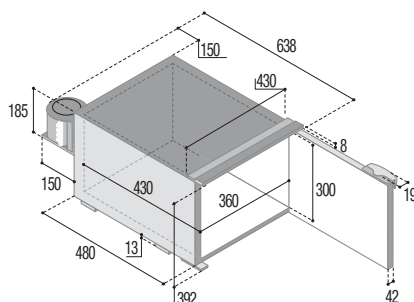

C33ip



Capacità totale - Total volume	33 lt.
Peso netto - Net weight	15 kg.
Alimentazione e consumo nominale Power supply and nominal consumption	12/24 Vdc 31 W

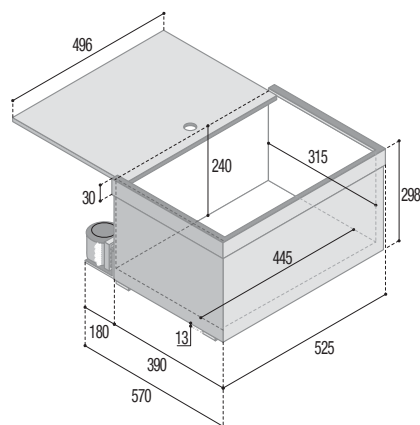

KIT MAN

Capacità totale - Total volume	70 lt. max
Peso netto - Net weight	6 kg.
Alimentazione e consumo nominale Power supply and nominal consumption	12/24 Vdc 26 W
Specifico per - Suitable for	MAN

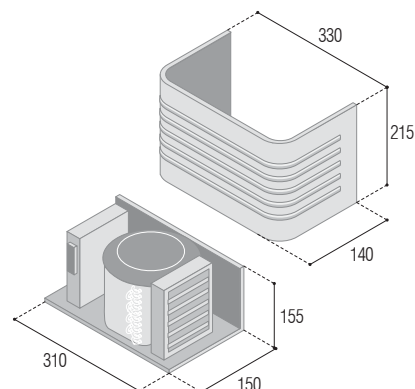

Frigoriferi e freezer trivalenti



Con un moderno reparto dedicato alla produzione di gruppi ad assorbimento, Vitrifrigo è una delle poche aziende presenti sul mercato in grado di presentare una completa gamma di frigoriferi trivalenti (12Vdc/230Vac/gas).

Frigoriferi con capacità variabile tra i 40 ed i 150 litri pienamente intercambiabili con gli equivalenti prodotti esistenti sul mercato.

Disponibili in **versione ES** (solo modello 5040), in cui la regolazione della temperatura interna è affidata ad un termostato elettronico e ad una valvola gas a tre posizioni e in **versione DG** (tutti gli altri modelli), in cui il termostato è sostituito da una scheda elettronica che permette il controllo delle funzioni. Entrambe le versioni sono provviste di un interruttore che consente di ottenere la ventilazione forzata dell'impianto (disponibile come optional), senza apportare alcuna modifica. Per installazioni stand-alone, (ad es.in una baita), è disponibile la **versione TOP**, con alimentazione 230Vac/gas e copertura superiore in metallo. Tutti i modelli della gamma sono disponibili anche in questa versione, tranne il modello 5040.

With a modern division dedicated to the manufacture of absorption units, Vitrifrigo is one of the market's few industries able to offer a full range of 3 ways refrigerators (12Vdc/230Vac/gas).

These models have a capacity that varies from between 40 to 150 litres and are fully interchangeable with any equivalent model on the market.

Available in **ES version** (model 5040 only), where the internal temperature is adjusted by electronic thermostat and with a 3 ways gas valve, or in the **DG version** (all other models), where the thermostat has been replaced by an electronic board to allow controlling the different functions. Both versions have a switch for forced system ventilation (available as an optional extra), without the need for any changes.

For stand-alone installation, such as in a chalet, for example, there is also a **TOP version**, with 230Vac/gas power and metal top cover.

All models in the range are also available in this version, except for the 5040.



VERSIONE TOP - TOP VERSION

Modelli disponibili Available models	Capacità totale Total volume
	Litri - Liters
5150	150
5105	92
5075 (5090)	72 (84)
5070 (5080)	61,5 (74)
5060	51
5040	40

Vedere legenda codici (pag. 58)

See code chart (page 58)

VTR5150DG

Capacità totale - Total volume	150 lt.
Vano freezer - Freezer compartment	25,2 lt.
Peso netto - Net weight	48,6 kg.
Alimentazione e consumo nominale Power supply and nominal consumption	12/230 Vdc 190 W gas - 23,9 g/h

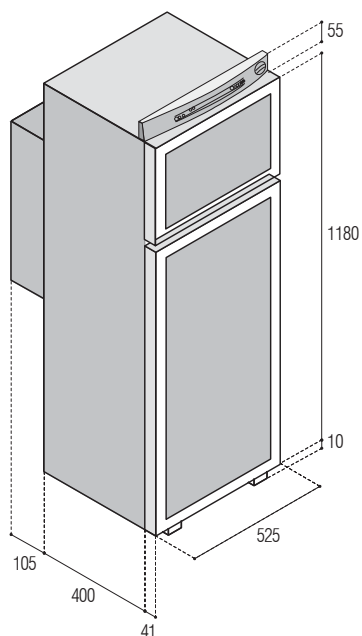

VTR5105DG

Capacità totale - Total volume	92 lt.
Vano freezer - Freezer compartment	12,3 lt.
Peso netto - Net weight	31,3 kg.
Alimentazione e consumo nominale Power supply and nominal consumption	12/230 Vdc 110 W gas - 19,7 g/h

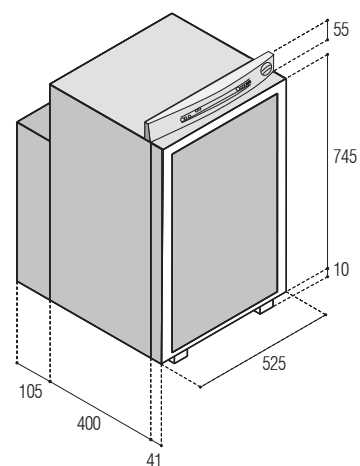

VTR5075DG VTR5090DG

	5075	5090
Capacità totale - Total volume	72 lt.	84 lt.
Vano freezer - Freezer compartment	8,2 lt.	11 lt.
Peso netto - Net weight	28 kg.	30 kg.
Alimentazione e consumo nominale Power supply and nominal consumption	12/230 Vdc 110 W gas - 19,7 g/h	

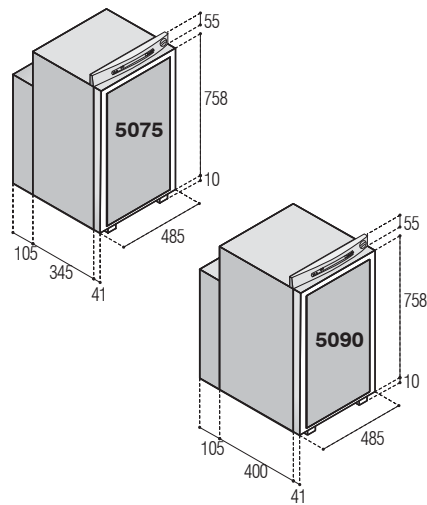

VTR5070DG VTR5080DG

	5070	5080
Capacità totale - Total volume	61,5 lt.	74 lt.
Vano freezer - Freezer compartment	8,3 lt.	11 lt.
Peso netto - Net weight	28 kg.	29,2 kg.
Alimentazione e consumo nominale Power supply and nominal consumption	12/230 Vdc 110 W gas - 19,1 g/h	

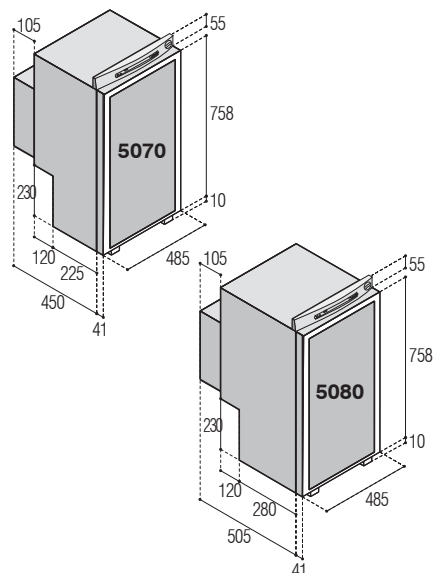

VTR5060DG

Capacità totale - Total volume	51 lt.
Vano freezer - Freezer compartment	6,9 lt.
Peso netto - Net weight	25,2 kg.
Alimentazione e consumo nominale Power supply and nominal consumption	12/230 Vdc 110 W
	gas - 19,1 g/h

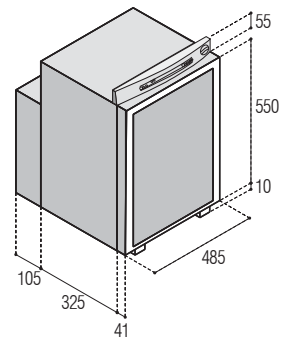

VTR5040ES

Capacità totale - Total volume	40 lt.
Peso netto - Net weight	15 kg.
Alimentazione e consumo nominale Power supply and nominal consumption	12/230 Vdc 70 W
	gas - 11 g/h

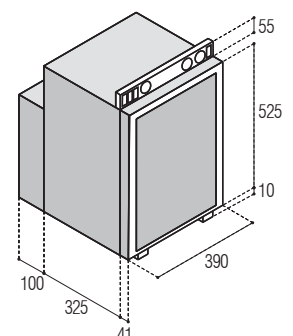

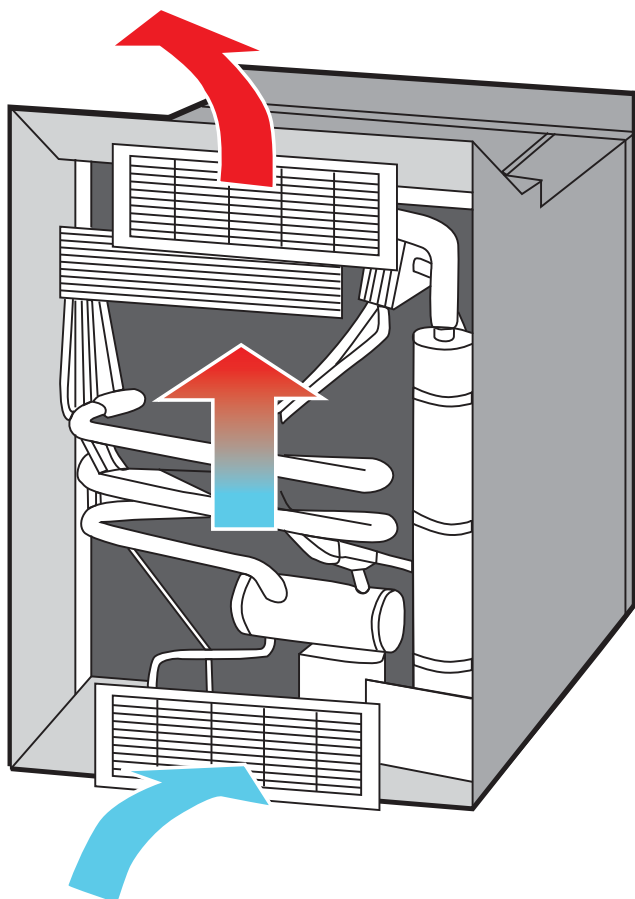

INSTALLAZIONE

Ogni frigorifero 3 ways installato ad incasso necessita di prese d'aria come da illustrazione.

Per un corretto funzionamento dell'impianto, è opportuno che la presa d'aria inferiore venga posizionata alla base del frigorifero e che la griglia superiore venga installata possibilmente sempre nella parte più alta.

Per migliorare la circolazione dell'aria, è possibile praticare dei fori sul pavimento sottostante all'impianto refrigerante, debitamente filtrati, onde evitare l'ingresso di impurità.

Per garantire in ogni condizione ambientale una perfetta efficienza del sistema refrigerante si consiglia l'installazione di griglie di aerazione superiore di tipo ventilato.

INSTALLATION

Each built-in 3 ways fridge, needs to utilize airflow grids as picture.

For a correct utilization of the system, is necessary that low airflow grid is positioned on the base of the fridge, the upper grid has to be installed possibly always on the top part.

To improve the airflow circulation, is possible to make some holes on the floor under the refrain plant, using filter to avoid impurity pollutions.

To guarantee a perfect efficiency of the system in all environment conditions, we advice to install upper ventilated type grids.

Vitrifigo technical department is always at your disposal for any further clarification.

PRESE D'ARIA A PARETE WALL-MOUNTED VENTILATION OPENINGS

GRIGLIA DI AERAZIONE SUPERIORE-INFERIORE VF STANDARD
TOP/BOTTOM VF STANDARD VENTILATED ON GRIDS

COD. R500.555



GRIGLIA DI AERAZIONE VENTILATA VF STANDARD
VF STANDARD VENTILATED GRID

COD. R500.560



KIT COPERTURA INVERNALE VF STANDARD
WINTER COVER KIT VF STANDARD

COD. R11583



SET DI PROLUNGHE PER SCARICO FUMI (*)
EXTENSION SET EXHAUST PIPE (*)

COD. R12894N.V



CAMINO ESTERNO (*)
EXTERNAL DUCT (*)

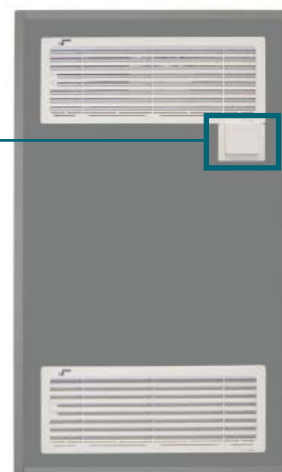

(*) Accessori in dotazione al frigorifero
Accessories supplied as standard

Frigoriferi e freezer con unità interna/esterna



L'evoluzione continua

La serie dei frigoriferi e freezer offre una gamma completa che copre tutte le esigenze in termini di spazio e di capacità.

Ergonomici, silenziosi, intuitivi e sicuri, in grado di garantire il massimo del confort a bordo del vostro camper e caravan.

Ora con il nuovo sistema "AIRLOCK".

The evolution continues

The refrigerators and freezers series offers a complete range that can meet any space or capacity requirements.

Ergonomic, silent, intuitive and safe, they are able to guarantee the best comfort on your camper and caravan.

Now with the new "AIRLOCK" system.

Modelli disponibili Available models	Capacità totale Total volume Litri - Liters
SLIM150	140
C130L	130
C95L	95
C75L	75
C75DW	75
C42L	42
C42DW	42
C25L	25
DP2600i	230
DP150i	150
C115i	115
C90i	90
C90DW	90
C85i	85
C62i	62
C60i	60
C51i	51
C51DW	51
C50i	50
C39i	39

Vedere legenda codici (pag. 58)

See code chart (page 58)

VERSIONI DISPONIBILI AVAILABLE VERSIONS



Versione "frigo+freezer" (foto di esempio: C115i)
"Fridge+freezer" version (example picture: C115i)



Versione "solo frigo" (foto di esempio: C115i)
"Fridge only" version (example picture: C115i)



DW Versione "a cassetto" (foto di esempio: C90DW)
"Drawer" version (example picture: C90DW)



Standard

Versione "Dark" senza profilo di fissaggio
"Dark" version without mounting flange

Disponibile anche in versione "Light"
Also available in "Light" version

Airlock. innovativo sistema di chiusura "intelligente"

Il nuovo sistema di chiusura Airlock offre 4 soluzioni integrate e innovative:

- 1) chiusura positiva della porta, per scongiurare le aperture accidentali;
- 2) unico profilo di fissaggio (optional), sia per la versione a incasso totale (door inside) che per quella a incasso parziale (door outside);
- 3) veloce reversibilità della porta: grazie ad un'accurata progettazione di tutti elementi del sistema, si effettua in tempi particolarmente rapidi;
- 4) sistema "vent position" integrato, per tenere la porta del frigo socchiusa, evitando così la formazione di odori sgradevoli e di muffa nei periodi di non utilizzo.

Due le versioni disponibili: **Light** che veste la tonalità luminosa del grigio perla, **Dark** nella quale viene dato ampio risalto al contrasto cromatico. Due interpretazioni in chiave grafica, che mirano ad esaltare proprio nel bianco e nel nero le linee, le geometrie e le texture dei materiali utilizzati, in relazione alle diverse esigenze d'immagine e di ambientazione del frigorifero.

New "SMART" locking system.

The new Airlock closure system integrates 4 innovative solutions:

- 1) positive door closure, to prevent unwanted openings;
- 2) unique Double purpose mounting flange (optional), for both partial built-in (door outside) or total built-in (door inside);
- 3) fast reversible opening: thanks to its smart design, it's now extremely quick and easy to operate;
- 4) integrated "vent position" system, to keep the fridge door ajar, preventing the formation of unpleasant odours and mould when not in use.

The new series is available in two brand new colours, very popular and elegant at the same time.

Two available versions: **Light** bright tones of pearl grey, and **Dark**, with an emphasis on the contrasting colours. Two graphic interpretations that aim to enhance the design, shapes and textures of the materials used, to meet the different needs in terms of image and surroundings of the refrigerator.



Optional

Versione "Dark" con profilo di fissaggio
"Dark" version with mounting flange

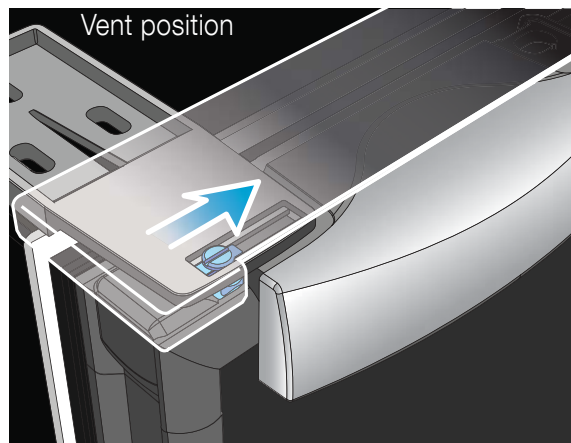

Optional

Versione "Light" con profilo di fissaggio
"Light" version with mounting flange

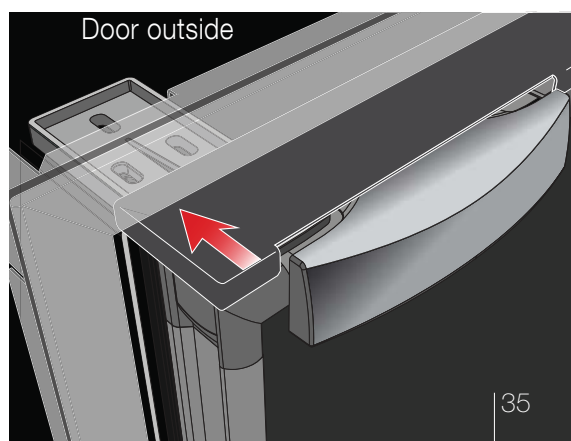
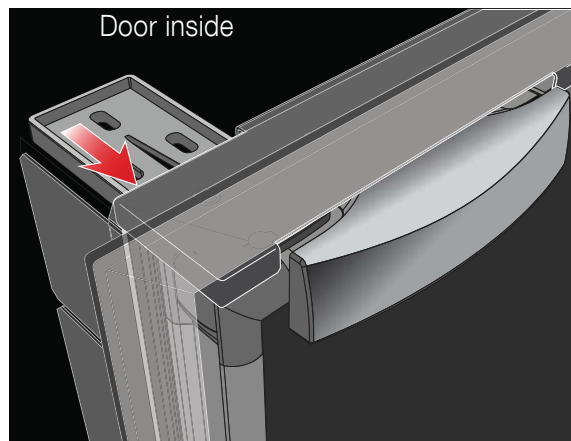

Frigoriferi e freezer con unità esterna

Refrigerators and freezers with remote cooling unit

SLIM150

Capacità totale - Total volume	140 lt.
Vano freezer - Freezer compartment	16 lt.
Peso netto - Net weight	42 kg.
Alimentazione e consumo nominale Power supply and nominal consumption	12/24 Vdc 47 W

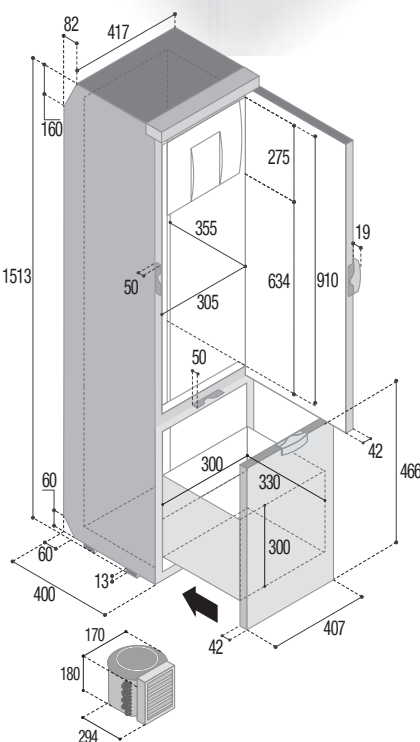

Disponibile come
Available as



H max
365 mm.



NIGHT MODE

Funzione di riduzione del rumore e del consumo energetico

Lowest noise level and reduced consumption during night time



TURBO MODE

Veloce raggiungimento della temperatura di raffreddamento desiderata

Fast chill set point temperature achieving



VENT POSITION

Mantiene socchiusa la porta evitando sgradevoli odori nei periodi di non utilizzo

It keeps the fridge door slightly open to prevent unpleasant odors due to not-working time



3-STAR FREEZER

Vano freezer da 16 litri per la conservazione dei cibi alla temperatura di -18°C

The 16-liter three-star freezer can store frozen food at a temperature of -18°C



C130L

Capacità totale - Total volume	130 lt.
Vano freezer - Freezer compartment	17,1 lt.
Peso netto - Net weight	27 kg.
Alimentazione e consumo nominale Power supply and nominal consumption	12/24 Vdc 45 W



Disponibile come
Available as

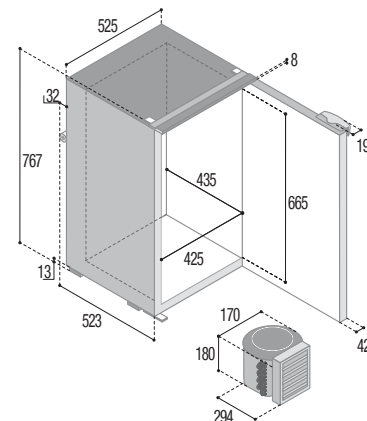

OPTIONAL

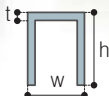

Profilo di fissaggio
Mounting flange

t: 25
w: 588
h: 804

Vano incasso
Built-in



Door
Inside

a: 560
b: 540
c: 768

Door
Outside

a: 518
b: 540
c: 768



Disponibile come
Available as



C95L

Capacità totale - Total volume	95 lt.
Vano freezer - Freezer compartment	12,8 lt.
Peso netto - Net weight	24 kg.
Alimentazione e consumo nominale Power supply and nominal consumption	12/24 Vdc 45 W

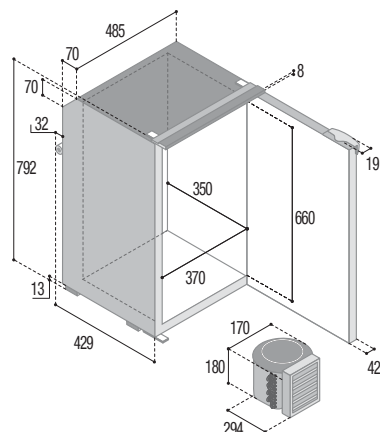

OPTIONAL

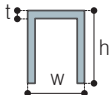

Profilo di fissaggio
Mounting flange

t: 25
w: 548
h: 829

Vano incasso
Built-in



Door
Inside

a: 466
b: 500
c: 793

Door
Outside

a: 424
b: 500
c: 793

C75L

Capacità totale - Total volume	75 lt.
Vano freezer - Freezer compartment	10,2 lt.
Peso netto - Net weight	20 kg.
Alimentazione e consumo nominale Power supply and nominal consumption	12/24 Vdc 40 W

Frigoriferi e freezer con unità esterna

Refrigerators and freezers with remote cooling unit

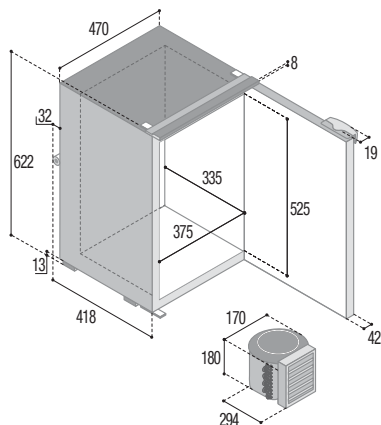

Disponibile come
Available as



OPTIONAL	Profilo di fissaggio Mounting flange	Vano incasso Built-in	Door Inside	Door Outside
	t: 25 w: 533 h: 659		a: 456 b: 485 c: 623	a: 413 b: 485 c: 623

C75DW

Capacità totale - Total volume	75 lt.
Vano freezer - Freezer compartment	10,2 lt.
Peso netto - Net weight	23 kg.
Alimentazione e consumo nominale Power supply and nominal consumption	12/24 Vdc 40 W

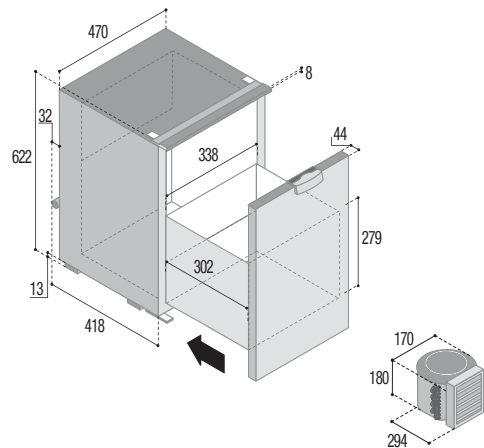

Disponibile come
Available as



OPTIONAL	Profilo di fissaggio Mounting flange	Vano incasso Built-in	Door Inside	Door Outside
	t: 25 w: 533 h: 659		a: 456 b: 485 c: 623	a: 413 b: 485 c: 623



H max
330 mm.



C42L

Capacità totale - Total volume	42 lt.
Vano freezer - Freezer compartment	3,6 lt.
Peso netto - Net weight	16 kg.
Alimentazione e consumo nominale Power supply and nominal consumption	12/24 Vdc 31 W



Disponibile come
Available as



OPTIONAL

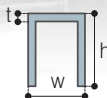

Profilo di fissaggio
Mounting flange

t: 25
w: 443
h: 569

Vano incasso
Built-in

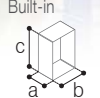

Door
Inside

a: 379
b: 395
c: 533

Door
Outside

a: 337
b: 395
c: 533

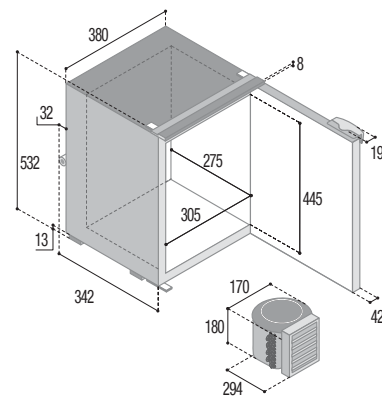

C42DW

Capacità totale - Total volume	42 lt.
Peso netto - Net weight	19 kg.
Alimentazione e consumo nominale Power supply and nominal consumption	12/24 Vdc 31 W



Disponibile come
Available as



OPTIONAL

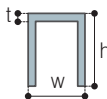

Profilo di fissaggio
Mounting flange

t: 25
w: 443
h: 569

Vano incasso
Built-in

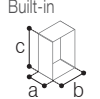

Door
Inside

a: 379
b: 395
c: 533

Door
Outside

a: 337
b: 395
c: 533



H max
420 mm.

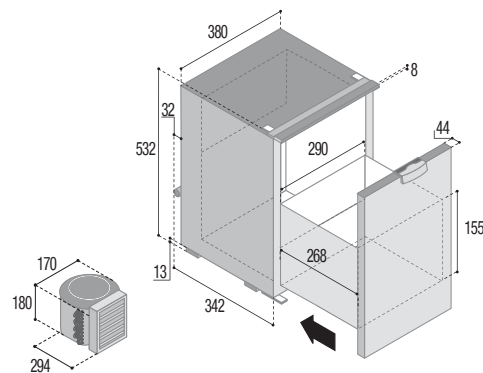

C25L

Capacità totale - Total volume	25 lt.
Peso netto - Net weight	13 kg.
Alimentazione e consumo nominale Power supply and nominal consumption	12/24 Vdc 34 W



Disponibile come
Available as



OPTIONAL

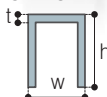

Profilo di fissaggio
Mounting flange

t: 25
w: 484
h: 454

Vano incasso
Built-in

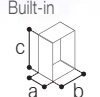

Door
Inside

a: 322
b: 439
c: 433

Door
Outside

a: 280
b: 439
c: 433

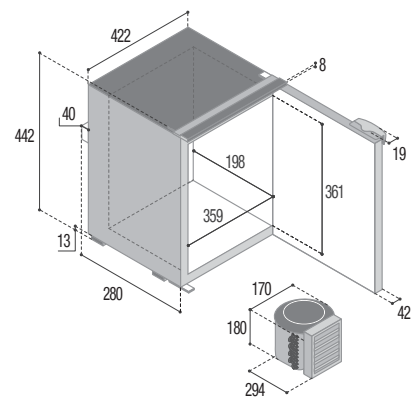

DP2600i

Capacità totale - Total volume	230 lt.
Vano freezer - Freezer compartment	60 lt.
Peso netto - Net weight	62 kg.
Alimentazione e consumo nominale Power supply and nominal consumption	12/24 Vdc 65 W

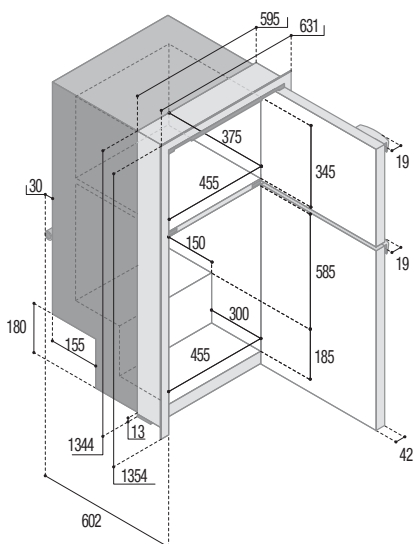

Disponibile solo come
Only available as





DP150i

Capacità totale - Total volume	150 lt.
Vano freezer - Freezer compartment	30 lt.
Peso netto - Net weight	43 kg.
Alimentazione e consumo nominale Power supply and nominal consumption	12/24 Vdc 65 W



OPTIONAL

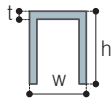

Profilo di fissaggio
Mounting flange

t: 25
w: 588
h: 1107



Vano incasso
Built-in

Door Inside	Door Outside
a: 565	a: 523
b: 540	b: 540
c: 1095	c: 1095

Disponibile solo come
Only available as

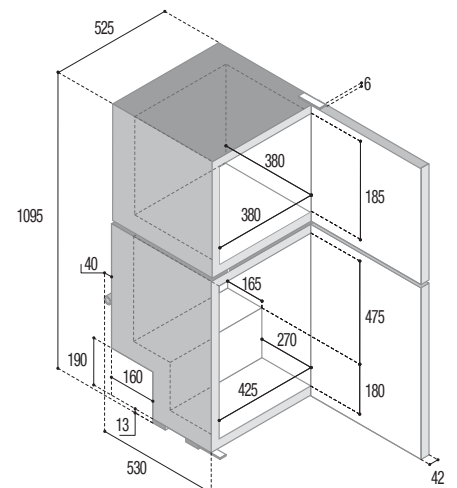

Dimensioni versione standard (senza profilo di fissaggio)
Standard version dimensions (no mounting flange)

C115i

Capacità totale - Total volume	115 lt.
Vano freezer - Freezer compartment	17,1 lt.
Peso netto - Net weight	23 kg.
Alimentazione e consumo nominale Power supply and nominal consumption	12/24 Vdc 45 W

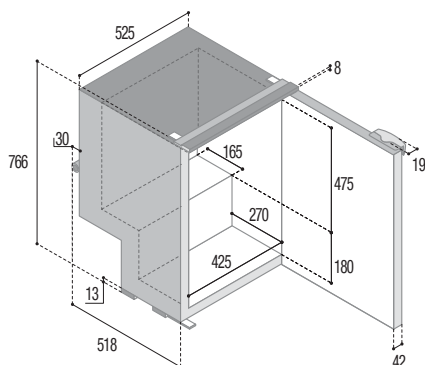

Disponibile come
Available as



OPTIONAL	Profilo di fissaggio Mounting flange	Vano incasso Built-in	Door Inside	Door Outside
	t: 25 w: 588 h: 804		a: 556 b: 540 c: 768	a: 513 b: 540 c: 768

C90i

Capacità totale - Total volume	90 lt.
Vano freezer - Freezer compartment	9,1 lt.
Peso netto - Net weight	22 kg.
Alimentazione e consumo nominale Power supply and nominal consumption	12/24 Vdc 45 W

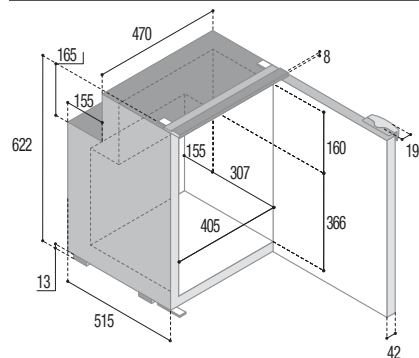

Disponibile come
Available as



OPTIONAL	Profilo di fissaggio Mounting flange	Vano incasso Built-in	Door Inside	Door Outside
	t: 25 w: 533 h: 659		a: 552 b: 485 c: 623	a: 510 b: 485 c: 623

C90DW

Capacità totale - Total volume	90 lt.
Vano freezer - Freezer compartment	9,1 lt.
Peso netto - Net weight	25 kg.
Alimentazione e consumo nominale Power supply and nominal consumption	12/24 Vdc 45 W

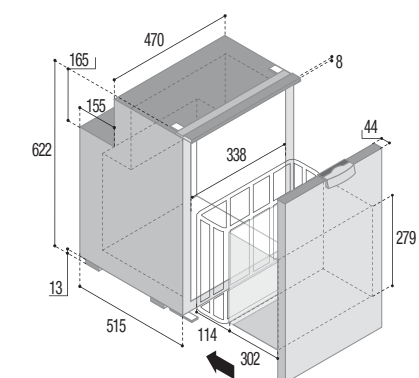

Disponibile come
Available as



OPTIONAL	Profilo di fissaggio Mounting flange	Vano incasso Built-in	Door Inside	Door Outside
	t: 25 w: 533 h: 659		a: 552 b: 485 c: 623	a: 510 b: 485 c: 623



H max
280 mm.

Refrigerators and freezers with built-in cooling unit



C85i

Capacità totale - Total volume	85 lt.
Vano freezer - Freezer compartment	12,8 lt.
Peso netto - Net weight	25 kg.
Alimentazione e consumo nominale Power supply and nominal consumption	12/24 Vdc 45 W



Disponibile come
Available as

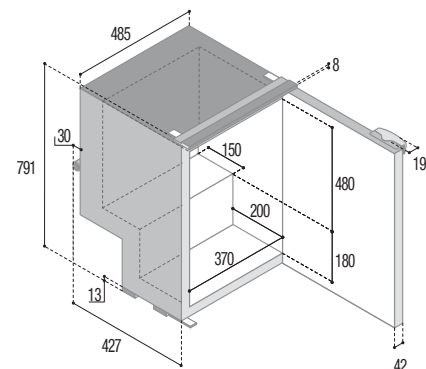

OPTIONAL	Profilo di fissaggio Mounting flange	Vano incasso Built-in	Door Inside	Door Outside
	t: 25 w: 548 h: 829		a: 464 b: 500 c: 792	a: 422 b: 500 c: 792

C62i

Capacità totale - Total volume	62 lt.
Vano freezer - Freezer compartment	4,5 lt.
Peso netto - Net weight	18 kg.
Alimentazione e consumo nominale Power supply and nominal consumption	12/24 Vdc 40 W



Disponibile come
Available as

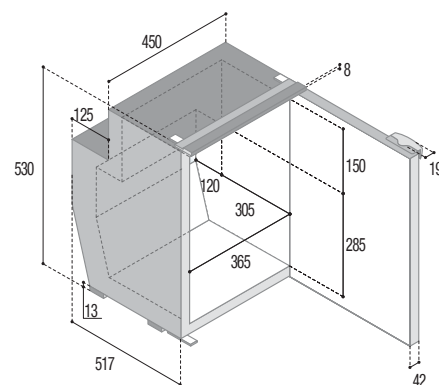

OPTIONAL	Profilo di fissaggio Mounting flange	Vano incasso Built-in	Door Inside	Door Outside
	t: 25 w: 513 h: 568		a: 554 b: 465 c: 533	a: 512 b: 465 c: 533

C60i

Capacità totale - Total volume	60 lt.
Vano freezer - Freezer compartment	10,2 lt.
Peso netto - Net weight	20 kg.
Alimentazione e consumo nominale Power supply and nominal consumption	12/24 Vdc 40 W

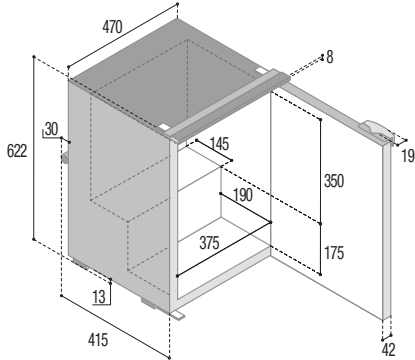

Disponibile come
Available as



OPTIONAL	Profilo di fissaggio Mounting flange	Vano incasso Built-in	Door Inside	Door Outside
t	t: 25	a	a: 453	a: 410
w	w: 533	b	b: 485	b: 485
h	h: 659	c	c: 623	c: 623

C51i

Capacità totale - Total volume	51 lt.
Vano freezer - Freezer compartment	3,6 lt.
Peso netto - Net weight	17 kg.
Alimentazione e consumo nominale Power supply and nominal consumption	12/24 Vdc 40 W

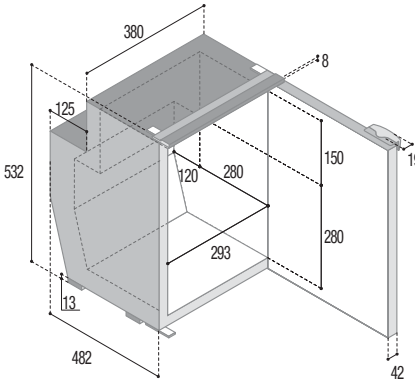

Disponibile solo come
Only available as



OPTIONAL	Profilo di fissaggio Mounting flange	Vano incasso Built-in	Door Inside	Door Outside
t	t: 25	a	a: 519	a: 477
w	w: 443	b	b: 395	b: 395
h	h: 569	c	c: 533	c: 533

C51DW

Capacità totale - Total volume	51 lt.
Vano freezer - Freezer compartment	3,6 lt.
Peso netto - Net weight	20 kg.
Alimentazione e consumo nominale Power supply and nominal consumption	12/24 Vdc 40 W

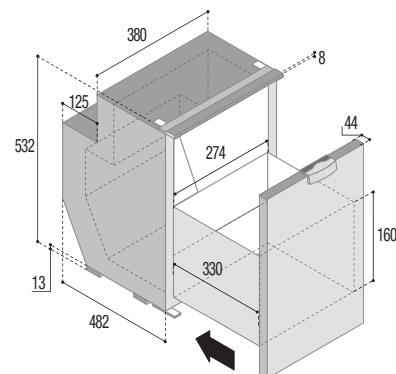

Disponibile solo come
Only available as



OPTIONAL	Profilo di fissaggio Mounting flange	Vano incasso Built-in	Door Inside	Door Outside
t	t: 25	a	a: 519	a: 477
w	w: 443	b	b: 395	b: 395
h	h: 569	c	c: 533	c: 533



Refrigerators and freezers with built-in cooling unit



C50i

Capacità totale - Total volume	50 lt.
Vano freezer - Freezer compartment	3,6 lt.
Peso netto - Net weight	17 kg.
Alimentazione e consumo nominale Power supply and nominal consumption	12/24 Vdc 40 W



Disponibile come
Available as

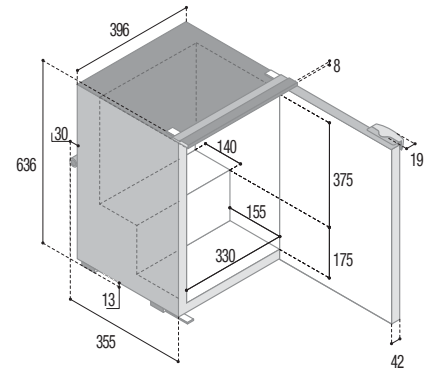

OPTIONAL	Profilo di fissaggio Mounting flange	Vano incasso Built-in	Door Inside	Door Outside
	t: 25 w: 459 h: 674		a: 393 b: 411 c: 638	a: 350 b: 411 c: 638

C39i

Capacità totale - Total volume	39 lt.
Vano freezer - Freezer compartment	3,6 lt.
Peso netto - Net weight	17 kg.
Alimentazione e consumo nominale Power supply and nominal consumption	12/24 Vdc 31 W



Disponibile come
Available as

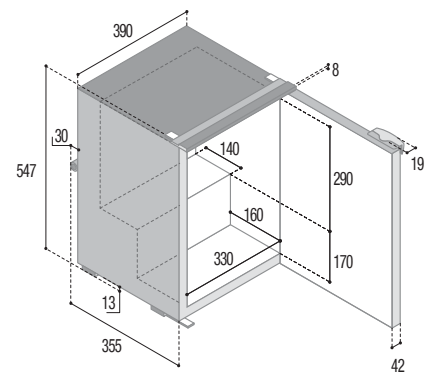

OPTIONAL	Profilo di fissaggio Mounting flange	Vano incasso Built-in	Door Inside	Door Outside
	t: 25 w: 453 h: 584		a: 393 b: 405 c: 548	a: 350 b: 405 c: 548

Frigoriferi portatili



Frigoriferi portatili

I vantaggi della portabilità sono declinati in tre modelli di differenti capacità. Costruiti in polietilene caricato ad alta resistenza mediante stampaggio rotazionale, offrono il massimo della robustezza, della piacevolezza estetica e dell'efficienza.

Portable refrigerators

Portable refrigerators are available in three different models and volumes. Made of high-strength polyethylene, using a roto-molding system, they offer the best durability and efficiency in an aesthetically pleasing style.

Modelli disponibili Available models	Capacità totale Total volume
	Litri - Liters
C65L - C65D	65
C41L - C41D	41
C29M - C29D	29



LA NUOVA SERIE DI FRIGORIFERI PORTATILI THE NEW SERIES OF PORTABLE REFRIGERATORS

Modelli disponibili Available models	Capacità totale Total volume
	Litri - Liters
VF65P	65
VF55P	55
VF45P	45
VF35P	35
VF16P	16

Frigoriferi portatili



Portateli ovunque

I frigoriferi portatili sono dotati di serie di maniglie per un agevole trasporto.

Per i modelli con maniglie pieghevoli, il fissaggio e la rotazione di queste ultime avviene mediante robusti perni in acciaio che mettono al riparo da rotture improvvise. Comfort e sicurezza sono, ancora una volta, un binomio indissolubile.

Bring them anywhere

Portable refrigerators provide foldable handles for easy carrying.

Handles are installed, using sturdy metal pins, to avoid sudden breakage.

Comfort and safety are, once more, an indispensable combination.



Illuminazione interna

Tutti i modelli di frigoriferi portatili sono dotati di serie di illuminazione interna a Led: basso assorbimento e alta efficienza per un utilizzo full time.

Internal lighting

Portable refrigerators are equipped with standard internal LED lighting: low power and high efficiency for full time use.



(a)

Temperatura sotto controllo

A seconda della tipologia di frigorifero portatile è possibile scegliere la soluzione che più si addice alle nostre esigenze, per mantenere la temperatura interna del frigorifero costantemente monitorata.



(b)

Temperature under control

Depending on the type of portable refrigerator, there are thermostat choices for the maintenance of desired internal temperatures.



(c)

(a) Termostato meccanico / Mechanical thermostat

(b) Termostato a Led / LED thermostat

(c) Termostato digitale / Digital thermostat

(a)

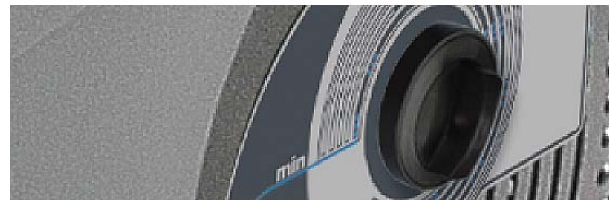

(b)



(c)





Organizzate il vostro tempo libero

I frigoriferi portatili sono dotati di serie di un pratico cestello interno a fili d'acciaio, estremamente utile per introdurre o estrarre facilmente tutto il contenuto del frigorifero.



Organize your free time

Portable refrigerators are equipped with a coated wire basket that is useful for loading and removing food and drinks easily.



Semplificarsi la vita

La staffa di fissaggio in dotazione standard dà la possibilità di ancorare saldamente e velocemente il frigorifero in uno spazio predeterminato.

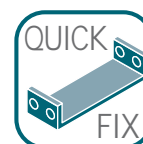

Make your life easier

The standard locking bracket allows to keep the refrigerator in place while underway.

eccetto C65
except for C65



Utilizzazione universale

In dotazione anche il cavo per l'alimentazione a batteria, con la presa universale per l'accendisigari.



Universal use

A 12Vdc cord is supplied for connecting the refrigerator to the car battery.

Frigoriferi portatili

C65L

C65D

Capacità totale - Total volume	65 lt.
Peso netto - Net weight	24 kg.
Alimentazione e consumo nominale Power supply and nominal consumption	12/24 Vdc 45 W

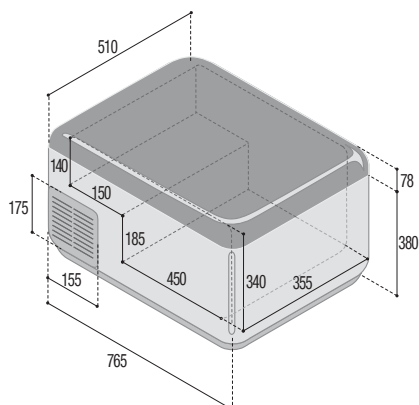

C41L

C41D

Capacità totale - Total volume	41 lt.
Peso netto - Net weight	17 kg.
Alimentazione e consumo nominale Power supply and nominal consumption	12/24 Vdc 43 W

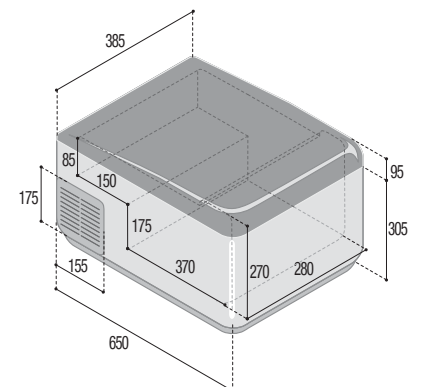

C29M

Capacità totale - Total volume	29 lt.
Peso netto - Net weight	15 kg.
Alimentazione e consumo nominale Power supply and nominal consumption	12/24 Vdc 48 W

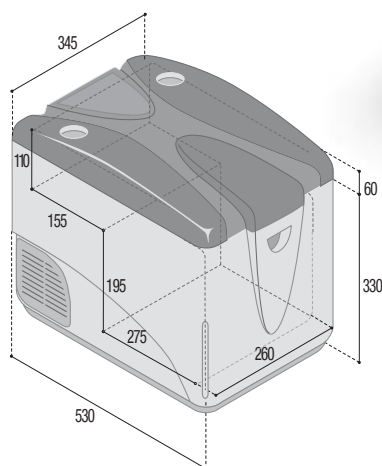

C29D

Capacità totale - Total volume	29 lt.
Peso netto - Net weight	15 kg.
Alimentazione Power supply	12/24 Vdc -100/240Vac 50/60Hz
Consumo nominale - Nominal consumption	48 W

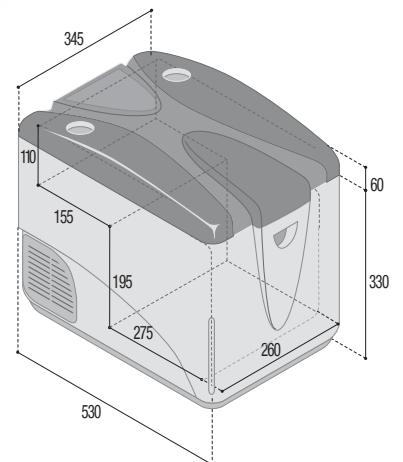



Compressore Secop

Secop compressor

Coperchio amovibile

Detachable lid

- ① **Pannello controlli digitale**
Digital control panel
- ② **Display led ad alta luminosità**
High brightness led display
- ③ **Funzione protezione batteria**
Battery protection function
- ④ **Presca caricabatterie USB**
Usb charging outlet



Cestello estraibile

Removable basket



Luce interna a led

Internal Led light



Alimentazione - Power supply 12/24Vdc - 100/240Vac 50/60Hz



VF65P



Capacità totale - Total volume	65 lt.
Peso netto - Net weight	23 kg.
Alimentazione e consumo nominale Power supply and nominal consumption	
12/24 Vdc -100/240Vac 50/60Hz	55 W

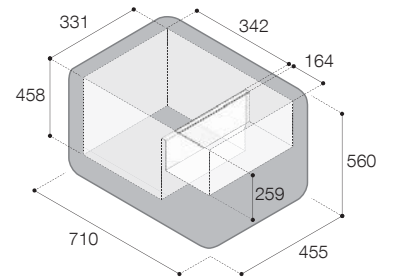

VF55P

Capacità totale - Total volume 55 lt.

Peso netto - Net weight 25 kg.

Alimentazione e consumo nominale
Power supply and nominal consumption

12/24 Vdc -100/240Vac 50/60Hz 55 W

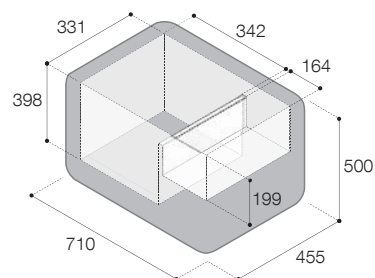

VF45P

Capacità totale - Total volume 45 lt.

Peso netto - Net weight 20,5 kg.

Alimentazione e consumo nominale
Power supply and nominal consumption

12/24 Vdc -100/240Vac 50/60Hz 55 W

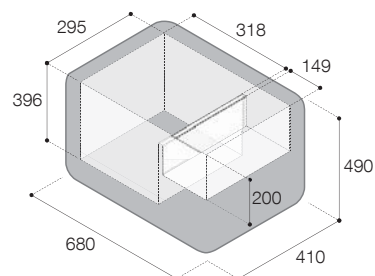

VF35P



Capacità totale - Total volume	35 lt.
Peso netto - Net weight	19,5 kg.
Alimentazione e consumo nominale Power supply and nominal consumption	
12/24 Vdc -100/240Vac 50/60Hz	55 W

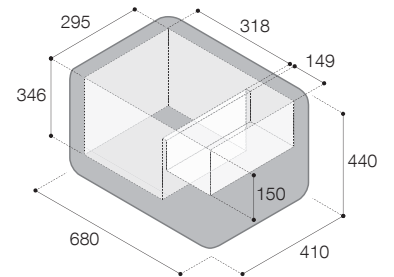

VF16P



Capacità totale - Total volume	16 lt.
Peso netto - Net weight	8 kg.
Alimentazione e consumo nominale Power supply and nominal consumption	
12/24 Vdc -100/240Vac 50/60Hz	45 W

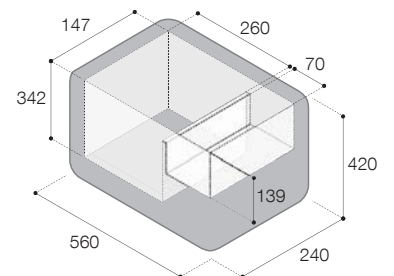

CLIMATIZZATORI AD USO STAZIONARIO

- RW** serie climatizzatori da parete Roadwind
- T** serie climatizzatori Roadwind da tetto

FRIGORIFERI AD INCASSO PER INSTALLAZIONI SPECIALI

- M** frigoriferi ad incasso specifici per Mercedes-Benz
- V** frigoriferi ad incasso specifici per Volvo
- S** frigoriferi ad incasso specifici per Scania
- C** frigoriferi e freezer con apertura porta frontale
- P** versione BRK35 con nuova chiusura PUSH-PULL

FRIGORIFERI E FREEZER TRIVALENTI

- VTR** serie frigo e freezer trivalenti
- ES** versione con termostato elettronico
- DG** versione con scheda elettronica
- TOP** versione 230Vac/gas e top in metallo

FRIGORIFERI E FREEZER CON UNITA' ESTERNA/INTERNA

- C** frigoriferi e freezer con apertura porta frontale
- DW** versione a cassetto
- DP** versione frigo con doppia porta
- I** versione con unità refrigerante interna
- L** versione con unità refrigerante esterna

FRIGORIFERI PORTATILI

- L** versione con termostato a LED
- D** versione con termostato digitale
- M** versione con termostato meccanico

AIR CONDITIONER FOR STATIONARY USE

- Roadwind series wall air conditioners
- Roadwind series roof air conditioners

BUILT-IN REFRIGERATORS FOR SPECIAL INSTALLATIONS

- built-in refrigerators suitable for Mercedes-Benz
- built-in refrigerators suitable for Volvo
- built-in refrigerators suitable for Scania
- refrigerator and freezers with front door opening
- BRK35 version with PUSH-PULL lock

3 WAYS REFRIGERATORS AND FREEZERS

- 3 ways refrigerators and freezers
- electronic thermostat version
- electronic board version
- 230Vac/gas power and metal top cover version

REFRIGERATORS AND FREEZERS WITH BUILT-IN/REMOTE UNIT

- refrigerator and freezers with front door opening
- drawer version
- double door refrigerator version
- built-in cooling unit version
- remote cooling unit version

PORTABLE REFRIGERATORS

- LED thermostat version
- digital thermostat version
- mechanical thermostat version

Ordini

Si invita la Spett.le Clientela ad inviare ordini solamente in forma scritta specificando chiaramente quanto segue:

- ragione sociale ed indirizzo completi di telefono, fax, e-mail;
- descrizione e codice prodotti;
- quantità;
- tipo di alimentazione;
- termini di consegna richiesti;
- vettore e modalità di consegna.

I Clienti che ci contattano per la prima fornitura dovranno indicare numero di Partita IVA e le coordinate bancarie (BBAN/ IBAN).

Pagamenti

La prima fornitura di merce considera il seguente pagamento:

- contrassegno vettore;
- bonifico bancario anticipato;
- pagamento garantito a mezzo fidejussione bancaria o garanzia accettata dalla Vitrifrigo.

Le forniture successive considereranno i pagamenti concordati con la rete vendita ed accettati dalla Vitrifrigo.

Per ordinativi di merce con importo netto inferiore a € 250,00 Vitrifrigo richiederà pagamento in contrassegno.

Per ordinativi di merce con importo netto inferiore a € 500,00 Vitrifrigo richiederà forma di pagamento in un'unica soluzione. Le spese riferite si intendono sempre a carico dell'acquirente.

Ritardi o irregolarità di pagamento daranno facoltà a Vitrifrigo di sospendere qualunque fornitura ed annullare contratti in essere applicando gli interessi di mora nei termini di legge vigenti.

Spedizioni

Le spedizioni delle merci in ordine si intendono sempre Franco Fabbrica e le merci viaggiano a rischio e responsabilità dell'acquirente.

Il destinatario deve :

- verificare eventuali danneggiamenti causati dal trasporto indicando eventuali riserve nella bolla di consegna;
- segnalare eventuali reclami in forma scritta entro 8 gg dal ricevimento della merce.

Vitfrigo declina ogni responsabilità per ritardi di consegna imputabili ai vettori.

Se non espressamente indicato dall'acquirente il Vettore verrà incaricato dalla Vitrifrigo.

Resi di materiali

Si accettano resi solo se preventivamente autorizzati da responsabili Vitrifrigo.

Gli stessi viaggiano a rischio e responsabilità dell'acquirente.

In caso di guasti o difetti di funzionamento contattare l'ufficio Service Vitrifrigo o un ns. Centro Assistenza Tecnica autorizzato.

Ricambi

Gli ordini relativi ai ricambi prevedono un importo minimo fatturabile di € 85 e l'aggiunta di € 15 (spese di gestione) per ordini di importo inferiore, escluse le spese di trasporto.

Foro competente

Per qualsiasi controversia, il foro competente è quello di Pesaro.

Vitfrigo si riserva il diritto di inserire in qualsiasi momento, e senza obbligo di preavviso, tutte le modifiche considerate opportune per ragioni tecniche o commerciali.

Orders.

We invite customers to send orders in writing only, specifying the following:

- full company name and address, telephone, fax and e-mail
- product description and code number
- quantity
- power supply type
- required delivery terms
- carrier and delivery type

Customers contacting us for first-time orders must indicate their VAT registration number and bank account details (BBAN/IBAN).

Payment.

First-time orders must be paid for as follows:

- cash on delivery
- advance bank transfer
- payment guaranteed by bank surety or by some other form of guarantee acceptable to Vitrifrigo.

Subsequent orders can be paid for as agreed with the sales network and accepted by Vitrifrigo.

For orders of goods where the net total is less than € 250.00, Vitrifrigo requires COD payment.

For orders of goods where the net total is less than € 500.00, Vitrifrigo will require payment in full.

Any bank charges named shall be met by the customer. Any arrears or irregularities in payments will entitle Vitrifrigo to suspend any supplies and to cancel any existing contracts with the application of interest on delayed payments in compliance with the laws in force.

Shipment.

Shipment of ordered goods is always Ex Works and goods travel at the exclusive risk and liability of the purchaser.

The intended recipient shall:

- check goods to ensure they comply with the order
- check for any damage that may have occurred during transport, indicating any reservations in the delivery note
- send any complaints in writing no later than 8 days from the receipt of goods.

Vitfrigo refuses to accept any liability for delays in delivery that can be attributed to the carrier.

Unless otherwise expressly named by the purchase, carriers will be appointed by Vitrifrigo.

Returns.

Returns will not be accepted without the prior authorisation of a Vitrifrigo official. Returned goods travel at the risk and liability of the purchaser. In the event of breakdowns or operating defects, contact the Service Division at Vitrifrigo or one of our authorised Technical Assistance Service Centres.

Spare parts.

We add a € 15 management fee to orders of spare parts under € 85. P&P is excluded.

Competent Court.

Any disputes will be regulated by the Court of Pesaro.

Vitfrigo reserves the right to make any changes it deems fit for technical or business purposes at any time and with no prior warning.

VITRIFRIGO

COOL AND BEYOND



Vitrifrigo S.r.l.

Via Mazzini, 75 - Frazione Montecchio - 61022 Vallefoglia (PU) - Italy

Tel. +39 0721 154.500

www.vitrifrigo.com - info@vitrifrigo.com