





Parete Vino

Sistema modulare per l'esposizione, conservazione e servizio del vino. L'inserimento di uno o più moduli gastronomia, salumeria o cioccolato consente di realizzare una pratica, elegante e ben distinta area dedicata esclusivamente all'esposizione enogastronomica.

Modular system for display, storage and serving of wine. The insertion of one or more modules, such as delicatessen, salami or chocolate, allows you to create a practical, elegant and distinct area exclusively dedicated to food and wine exhibition.

Système modulaire pour l'exposition, la conservation et le service de vin. L'ajout d'un ou plusieurs modules gastronomie, salaisons ou chocolat permet de réaliser un espace pratique, élégant et bien séparé réservé exclusivement à l'exposition de produits gastronomiques et oenologiques.

INSTALLAZIONE CON CORNICE

Frame installation • Installation avec encadrement



Appoggio
Standing
D'appui

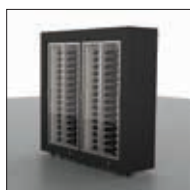

Centrale
Central
Central



Incasso
Built-in
A encastrement

SISTEMA MODULARE

Modular system • Système modulaire



Finiture Parete Vino

CORNICE LINEARE

Plain frame · Cadre linéaire



FN-CL

Colori disponibili

L01 - L10 - L11 - L20 - L21 - L22 - L23 - L40 - L50 - V01 - V02 - RAL

CORNICE SAGOMATA

Moulded frame · Cadre mouluré

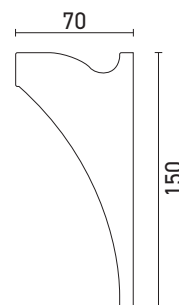

FN-CS

Colori disponibili

A01 - F01 - F02 - V01 - V02 - RAL

PANNELLI LATERALI

Side panels · Les panneaux latéraux



FN-PL

L'inserimento dei pannelli laterali è da prevedere esclusivamente nell'installazione "da appoggio" oppure "centrale".

Side panels are to be added exclusively in the case of "wall-back" or "central" installations.

L'introduction des panneaux latéraux ne doit être envisagée qu'en cas de choix de l'installation "d'appui" ou "centrale".

Colori disponibili

M01 - L10 - L11 - L20 - L21 - L22 - L23 - L40 - L50 - V01 - V02 - RAL

RIVESTIMENTO FIT

Fit cladding · Habillage Fit



FN-RF*1A

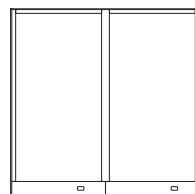

FN-RF*2A

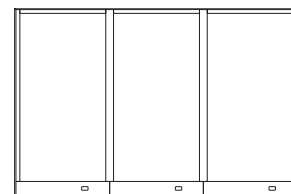

FN-RF*3A

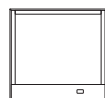

FN-RF*1D

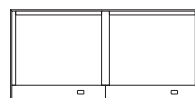

FN-RF*2D

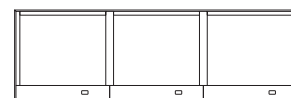

FN-RF*3D

Rivestimento completo top, fianchi e frontalino.

Complete cladding for top, sides and front flap.

Rèvetement complet du top, côtés et panneau de base ouvrable.

Colori disponibili

L01 - L10 - L11 - L20 - L21 - L22 - L23 - L40 - L50 - V01 - V02 - RAL

COLORS

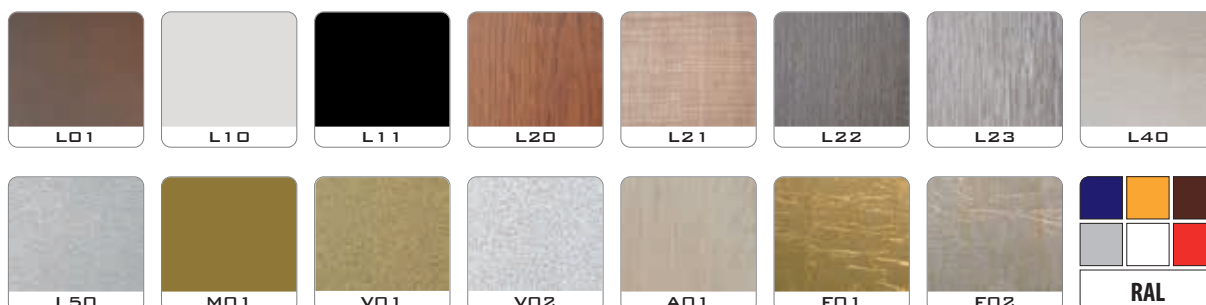

MODULI REFRIGERATI PER VINO

Wine cooling units • Modules réfrigérés pour vin



°C
+4 / +18



°C
+4 / +18

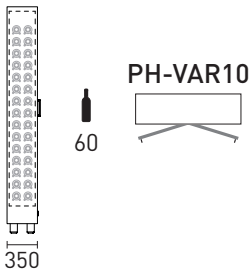

mm 900 x 350 x 1857

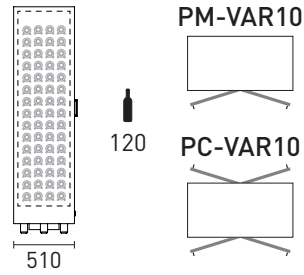

mm 900 x 510 x 1898

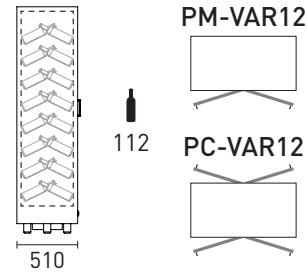

mm 900 x 510 x 1898





°C
+4 / +18



PM-VAR13



128

PC-VAR13

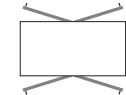

mm 900 x 510 x 1898



°C
+4 / +18

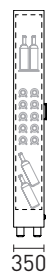

PH-VAR14



56 / 64

PC-VAR14



mm 900 x 350 x 1857



PM-VAR14

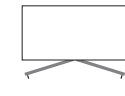

112 / 128

PC-VAR14

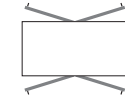

mm 900 x 510 x 1898



°C
+14 / +16



PM-VBR10



PC-VBR10

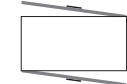

mm 900 x 510 x 1050



°C
+14 / +16



PM-VBR13



PC-VBR13

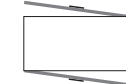

mm 900 x 510 x 1050



°C
+4 / +18

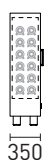

24

PH-VDR20

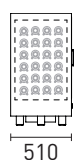

48

PM-VDR20



PC-VDR20

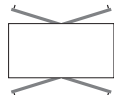

mm 900 x 350 x 902

mm 900 x 510 x 943



°C
+4 / +18



42

PM-VDR22



PC-VDR22

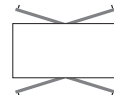

mm 900 x 510 x 943



°C
+4 / +18



64

PM-VDR23



PC-VDR23

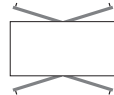

mm 900 x 510 x 943



°C
+4 / +18

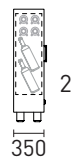

21/32

PH-VDR24



PM-VDR24



PC-VDR24

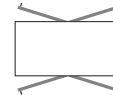

mm 900 x 350 x 902

mm 900 x 510 x 943



MODULI SALUMERIA

Salami modules • Modules salaisons



°C
+4 / +16



PM-SAR10



PC-SAR10

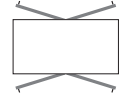

mm 900 x 510 x 1898



°C
+4 / +16

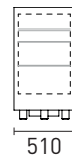

PM-SDR20



PC-SDR20

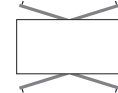

mm 900 x 510 x 943

MODULI GASTRONOMIA

Delicatessen modules • Modules gastronomie



°C
+4 / +8



PH-GAR10



350

mm 900 x 350 x 1857



PM-GAR10



PC-GAR10

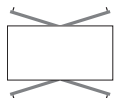

mm 900 x 510 x 1898



°C
+4 / +8



PH-GDR20



350

mm 900 x 350 x 902



PM-GDR20



PC-GDR20

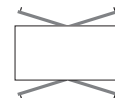

mm 900 x 510 x 943

MODULI CIOCCOLATO

Chocolate modules • Modules chocolat



°C
+14 / +16



PH-CAR10



350

mm 900 x 350 x 1857



PM-CAR10



PC-CAR10

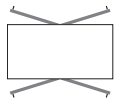

mm 900 x 510 x 1898



°C
+14 / +16

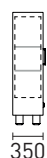

PH-CDR20



350

mm 900 x 350 x 902



PM-CDR20



PC-CDR20

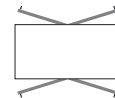

mm 900 x 510 x 943



Teca



La Teca ha una struttura in alluminio rivestita da una cornice in legno realizzabile con finiture e colori diversi. Questa scelta costruttiva permette di sostituire con semplicità sia le parti in vetro che la cornice in legno. La Teca è disponibile nella versione a profondità ridotta (H) con condensatore statico installato nella parte posteriore e nella versione standard (M / C) dove è installato l'innovativo sistema di refrigerazione centrale basato sul posizionamento della serpentina di raffreddamento al centro della vetrina. Questo sistema consente la costruzione della vetrina centrale (C) con porte scorrevoli su entrambi i lati.

Teca features a wooden-clad aluminum structure that comes in different colors and finishes. This design choice allows for easy replacement both of glass parts and the wood frame.

Teca is available with reduced depth (H) with static condenser installed in the back, and standard depth (M / C) equipped with the innovative central refrigeration system with the cooling coil in the middle of the cabinet. This system makes it possible to have a central (C) system with sliding doors on both sides.

La Teca a une structure en aluminium recouvert d'un cadre en bois qui peut être réalisé avec différentes finitions et couleurs. Ce choix constructif permet de remplacer facilement soit les parties en verre soit le cadre en bois. La Teca est disponible en version à profondeur réduite (H) avec condenseur statique installé à l'arrière et dans la version standard (M / C) où le système de réfrigération central innovant est conçu par le positionnement du serpentin de refroidissement au milieu de l'armoire. Ce système permet la construction de la vitrine centrale (C) avec des portes coulissantes sur des deux côtés.

COLORS

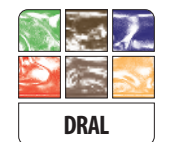



°C
+4 / +18

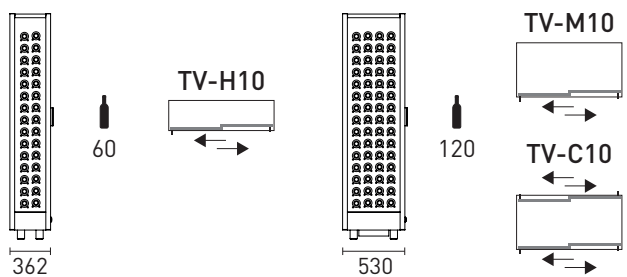

mm 860 x 362 x 1852



°C
+4 / +18

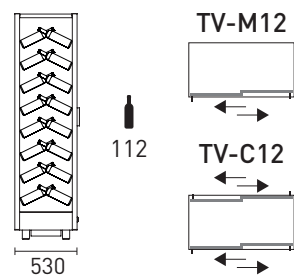

mm 860 x 530 x 1893



°C
+4 / +18

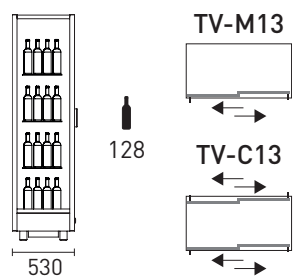

mm 860 x 530 x 1893



°C
+4 / +18

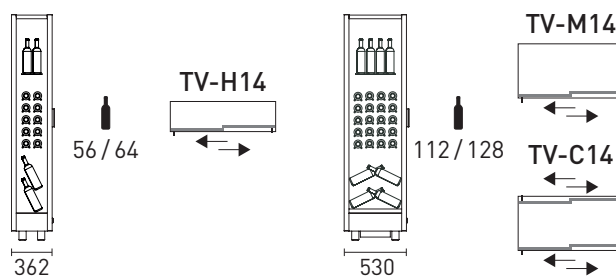

mm 860 x 362 x 1852

mm 860 x 530 x 1893



°C
+4 / +18

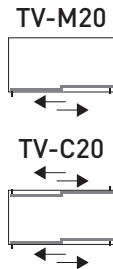
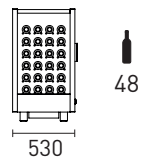
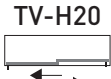
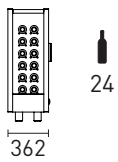

mm 860 x 362 x 897

mm 860 x 530 x 938



°C
+4 / +18

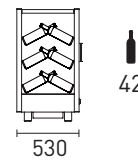

mm 860 x 530 x 938



°C
+4 / +18

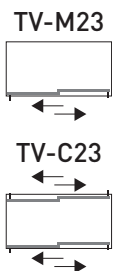
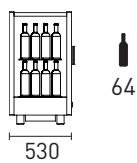

mm 860 x 530 x 938



°C
+4 / +18

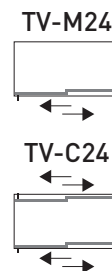
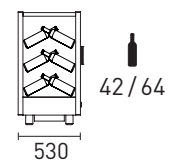
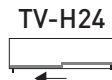
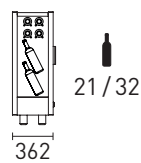

mm 860 x 362 x 897

mm 860 x 530 x 938



SALUMERIA

Salami • Salaisons



°C
+4 / +16



TS-M10



TS-C10

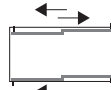

mm 860 x 530 x 1893



°C
+4 / +16



TS-M20



TS-C20

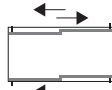

mm 860 x 530 x 938



°C
+4 / +8



°C
+4 / +8

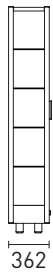

TG-H10

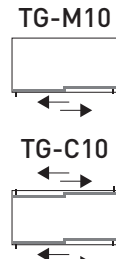
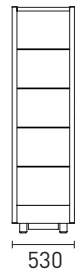

TG-M10

TG-C10

mm 860 x 362 x 1852

mm 860 x 530 x 1893

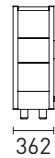

TG-H20

362

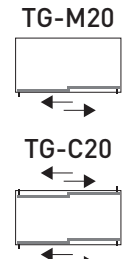
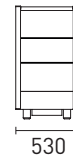

TG-M20

TG-C20

530

mm 860 x 362 x 897

mm 860 x 530 x 938





CIOCCOLATO

Chocolate • Chocolat



°C
+14 / +16

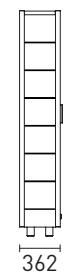

mm 860 x 362 x 1852



TC-H10

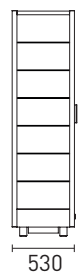

mm 860 x 530 x 1893

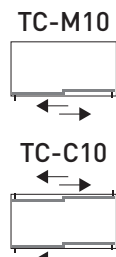

TC-M10

TC-C10



°C
+14 / +16



mm 860 x 362 x 897



TC-H20

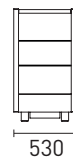

mm 860 x 530 x 938

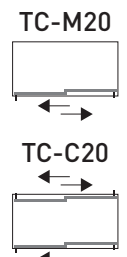

TC-M20

TC-C20



Teca B

Versione ad incasso della vetrina Teca.

La Teca B è semplice da installare in nicchie o passaggi inutilizzati. La cornice è applicata con sistema ad incastro per cui facilmente sostituibile per qualsiasi esigenza tecnica o commerciale.

Built-in version of the Teca model.

Teca B is easy to install in recesses or unused spaces. The frame is mounted with a snap-on system, making it easy to replace for any technical or commercial need.

Version encastrée de la vitrine Teca.

Teca B est facile à installer dans des niches ou des passages inutilisés. Le cadre est appliqué avec un système d'emboiture et peut être facilement remplacé pour n'importe quel besoin technique ou commercial.

COLORS



VINO
Wine • Vin



+4 / +18

TBV-H10 60
mm 880 x 358 x 1862

TBV-M10 120
mm 880 x 530 x 1901



+4 / +18

TBV-M12 112
mm 880 x 530 x 1901



+4 / +18

TBV-M13 128
mm 880 x 530 x 1901



+4 / +18

TBV-H14 56 / 64
mm 880 x 358 x 1862

TBV-M14 112 / 128
mm 880 x 530 x 1901

SALUMERIA
Salami • Salaisons



+4 / +16

TBS-M10
mm 880 x 530 x 1901

GASTRONOMIA
Delicatessen • Gastronomie



+4 / +8

TBG-H10 TBG-M10
mm 880 x 358 x 1862 mm 880 x 530 x 1901

CIOCCOLATO
Chocolate • Chocolat



+14 / +16

TBC-H10 TBC-M10
mm 880 x 358 x 1862 mm 880 x 530 x 1901



Teca M

MODULAR
MAGNETIC



Sistema modulare con cover di finitura ad applicazione magnetica.

Modular system with magnetic finishing covers.

Système modulaire à coques de finition aimantées.



L'applicazione della Cover è magnetica.
The fixing of the cover is magnetic.
L'application de la Cover est magnétique.



Applicare la Cover "U" magnetica per coprire il punto d'unione, rifinire ed armonizzare la composizione.
Fix the "U" magnetic Cover to hedge the juncture between the showcases, finishing and harmonizing the composition.
Appliquez la Cover "U" magnétique pour chacher et terminer le point d'union entre les vitrines.

COVER

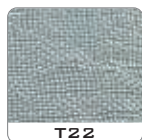
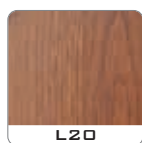

MODULI REFRIGERATI PER VINO

Wine cooling units • Modules réfrigérés pour vin



°C
+4 / +18

TMV-H10 60
mm 860 x 361 x 1850

TMV-M10 • TMV-C10 120
mm 860 x 530 x 1891



°C
+4 / +18

TMV-M12 • TMV-C12 112
mm 860 x 530 x 1891



°C
+4 / +18

TMV-M13 • TMV-C13 128
mm 860 x 530 x 1891



°C
+4 / +18

TMV-H14 56 / 64
mm 860 x 361 x 1850

TMV-M14 • TMV-C14 112 / 128
mm 860 x 530 x 1891



°C
+4 / +18

TMV-H20 24
mm 860 x 361 x 895

TMV-M20 • TMV-C20 48
mm 860 x 530 x 936



°C
+4 / +18

TMV-M22 • TMV-C22 42
mm 860 x 530 x 936



°C
+4 / +18

TMV-M23 • TMV-C23 64
mm 860 x 530 x 936



°C
+4 / +18

TMV-H24 21 / 32
mm 860 x 361 x 895

TMV-M24 • TMV-C24 42 / 64
mm 860 x 530 x 936

MODULI SALUMERIA

Salami modules • Modules salaisons



+4 / +16

TMS-M10 • TMS-C10

mm 860 x 530 x 1891



+4 / +16

TMS-M20 • TMS-C20

mm 860 x 530 x 936

MODULI GASTRONOMIA

Delicatessen modules • Modules gastronomie



+4 / +8

TMG-H10

mm 860 x 361 x 1850

TMG-M10 • TMG-C10

mm 860 x 530 x 1891



+4 / +8

TMG-H20

mm 860 x 361 x 895

TMG-M20 • TMG-C20

mm 860 x 530 x 936

MODULI CIOCCOLATO

Chocolate modules • Modules chocolat



+14 / +16

TMC-H10

mm 860 x 361 x 1850

TMC-M10 • TMC-C10

mm 860 x 530 x 1891



+14 / +16

TMC-H20

mm 860 x 361 x 895

TMC-M20 • TMC-C20

mm 860 x 530 x 936



Quadro Vino



Design e tecnologia si fondono per dar vita al primo quadro refrigerato mai realizzato al mondo. Un oggetto assolutamente innovativo, dal design raffinato, capace di rendere speciale ogni ambiente in cui è inserito.

Design and technology combined to create the first refrigerated frame in the world. A greatly innovative article with sophisticated design that will make any location special.

Design et technologie ensemble pour créer le premier cadre réfrigéré jamais réalisé dans le monde. Un objet absolument innovant, design sophistiqué, capable de rendre spécial tout environnement dans lequel il est inséré.

COLORS

CORNICI • FRAMES • CADRES



PANNELLI • PANELS • PANNEAUX





Quadro Vino n. 12



QV12

 °C
 + 4 / +10

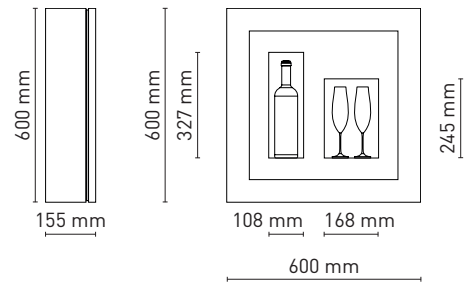

Quadro Vino n. 30



QV30

 °C
 + 8 / +20

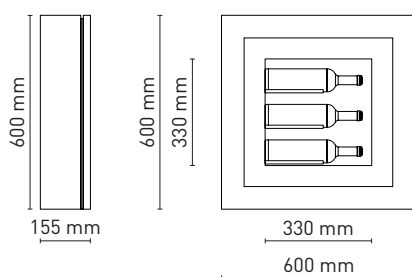

Quadro Vino n. 40



QV40



+ 12 / +20

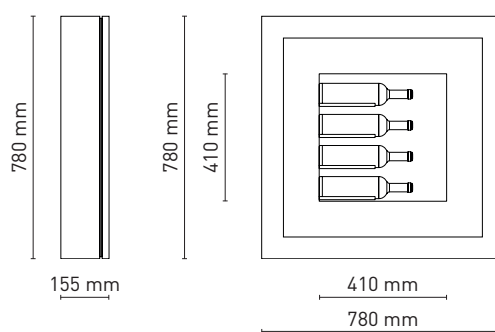

Quadro Vino n. 52



QV52



+ 12 / +20

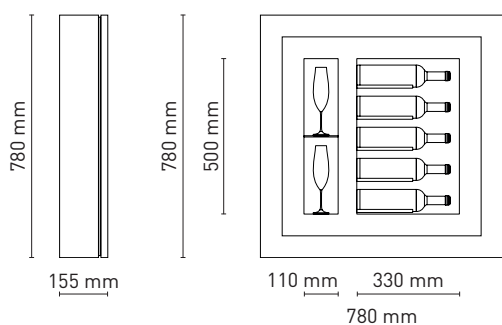

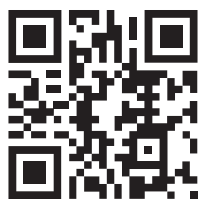

EXPO' SRL

Via G. Di Vittorio, 11 • 10098 Rivoli (TO) • ITALY
www.exposrl.com • info@exposrl.com

